



*The Signature of Quality®*

## INSTALLATION & OPERATIONS INSTRUCTIONS



**ECGR50, ECGR59, ECGR77**  
**ECGD50, ECGD59, ECGD77**



**ECGR50CD, ECGR59CD, ECGR77CD**

**KEEP THIS MANUAL FOR FUTURE REFERENCE**

Engineering and technical data are subject to change without notice.

# CONTENTS

<b>INTRODUCTION.....</b>	<b>3</b>
<b>WARNING LABELS &amp; SAFETY INSTRUCTIONS .....</b>	<b>4</b>
<b>PRE-INSTALLATION PROCEDURES .....</b>	<b>5</b>
Inspection For Shipping Damage.....	5
<b>INSTALLATION INSTRUCTIONS.....</b>	<b>5</b>
Locating The Display Case.....	5
Removing Case From Shipping Skid.....	5
Grill Removal.....	6
Condensate Evaporator .....	7
Cleaning .....	7
Refrigeration Installation .....	7
<b>ELECTRICAL INFORMATION &amp; GROUNDING.....</b>	<b>8</b>
<b>OPERATING INSTRUCTIONS.....</b>	<b>9</b>
Controls.....	9
Shelves .....	9
Rear Package Shelf .....	9
Doors.....	9
Placing Product Into Case.....	10
<b>SHELVING INSTALLATION &amp; REMOVAL.....</b>	<b>11-13</b>
Shelves and shelf light quantity .....	13
<b>SHELF INSTALLATION.....</b>	<b>13</b>
Wire Shelves .....	13
Metal Shelves.....	13
<b>MAINTENANCE.....</b>	<b>14</b>
Fluorescent Shelf Light Bulb Replacement .....	14
Fluorescent Top Light Bulb Replacement .....	14
LED Shelf Light Replacement.....	15
LED Top Light Replacement.....	16
<b>PERIODIC MAINTENANCE.....</b>	<b>17</b>
Cleaning Condenser Coil .....	17
<b>CLEANING INSTRUCTIONS.....</b>	<b>18-20</b>
Daily Cleaning .....	18
Weekly Cleaning.....	19
Interior Cleaning.....	19-20
Exterior Cleaning.....	20
<b>SERVICE INFORMATION .....</b>	<b>21</b>
Pre-Service Checklist.....	21-22
Special Service Situations.....	23
<b>SALE &amp; DISPOSAL.....</b>	<b>23</b>
Owner Responsibility.....	23
<b>REFRIGERATION &amp; ELECTRICAL DATA .....</b>	<b>24</b>
<b>MAIN WIRING DIAGRAMS .....</b>	<b>25-26</b>
<b>LIGHT WIRING DIAGRAMS .....</b>	<b>27-30</b>
Fluorescent Light Wiring Diagrams .....	27-29
LED Light Wiring Diagrams .....	30
<b>REPLACEMENT PARTS .....</b>	<b>31-32</b>

---

---

# INTRODUCTION

---

---

Thank you for purchasing a Federal Industries display case. This manual contains important instructions for installing and servicing the Curved Glass and Hi-Volume Refrigerated (including Dual Zone & Cold Deli) and Non-Refrigerated Display Cases. A repair parts list and wiring diagram are also included in the manual. Read all of these documents carefully before installing or servicing your case.



## NOTICE

**Read this manual before installing your case. Keep this manual and refer to it before doing any service on the equipment. Failure to do so could result in personal injury or damage to the case.**



## NOTICE

**Installation and service of the electrical components in the case must be performed by a licensed electrician.**

The portions of this manual covering components contain technical instructions intended only for persons qualified to perform electrical work.



## DANGER

**Improper or faulty hookup of electrical components in the case can result in severe injury or death.**

**All electrical wiring hookups must be done in accordance with all applicable local, regional, or national standards.**

## SERIAL NUMBER

Record the model and serial numbers of the case for easy reference. Always refer to both model and serial numbers in your correspondence regarding the case.

Case Model \_\_\_\_\_ Serial Number \_\_\_\_\_  
Condensing Unit Model \_\_\_\_\_ Serial Number \_\_\_\_\_

This manual cannot cover every installation, use, or service situation. If you need additional information, call or write us:

**CUSTOMER SERVICE DEPARTMENT**  
**Federal Industries**  
**215 Federal Avenue**  
**Belleville, WI 53508**  
**Toll Free (800) 356-4206 / WI Phone (608) 424-3331**

---

---

# WARNING LABELS & SAFETY INSTRUCTIONS

---

---



This is the safety-alert symbol. When you see this symbol on your case or in the manual, be alert to the potential for personal injury or damage to your equipment.

Be sure you understand all safety messages and always follow recommended precautions and safe operating procedures.



## NOTICE TO EMPLOYERS

**You must make sure that everyone who installs, uses, or services your case is thoroughly familiar with all safety information and procedures.**

Important safety information is presented in this section and throughout the manual. The following signal words are used in the warning and safety messages:

**DANGER:** Severe injury or death will occur if you ignore the message.

**WARNING:** Severe injury or death can occur if you ignore the message.

**CAUTION:** Minor injury or damage to your case can occur if you ignore the message.

**NOTICE:** This is important installation, operation, or service information. If you ignore the message, you may damage your case.

---

---

The warning and safety labels shown throughout this manual are placed on your Federal Industries case at the factory. Follow all warning label instructions. If any warning or safety labels become lost or damaged, call our customer service department at 1(800) 356-4206 for replacements.

---

---

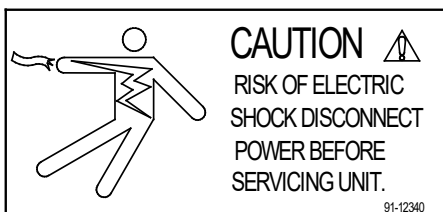

*This label is located on the back of the display case.*

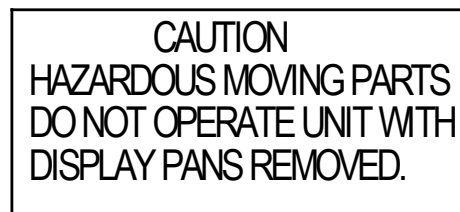

*This label is located below the display pan.*

---

---

# PRE-INSTALLATION PROCEDURES

---

---

## Inspection for Shipping Damage

You are responsible for filing all freight claims with the delivering truck line. Inspect all cartons and crates for damage as soon as they arrive. If damage is noted to shipping crates, cartons, or if a shortage is found, note this on the bill of lading (all copies) prior to signing.

If damage is discovered when the case is uncrated, immediately call the delivering truck line and follow up the call with a written report indicating concealed damage to your shipment. Ask for an immediate inspection of your concealed damage item. Crating material must be retained to show the inspector from the truck line.

---

---

# INSTALLATION INSTRUCTIONS

---

---

## Locating the Display Case

The case should be located where it is not subjected to the direct rays of the sun, heating ducts, grills, radiator, or ceiling fans, nor should it be located near open doors or main door entrances. Also, avoid locations where there are excessive air movement or air disturbances.

On refrigerated models the condenser air inlet and discharge is located at the rear of the case. Do not block this inlet and do not locate the air inlet near a source of heat.

## Removing Case From Shipping Skid



**CAUTION: Do not push against the top glass, front glass, end glass, doors or door frames when removing the case from the skid or moving the case. Case damage or glass breakage could result.**

1. Remove crate top and sides and note missing or damaged items as explained in the pre-installation procedures outlined above.
2. Move the case as near as possible to the final location and before removing it from the shipping skid.
3. If your case is supplied with plastic end panels, remove them by lifting them in an upward direction. Set these end panels aside to be reinstalled after case is placed in proper position.
4. Remove the (4) brackets that secure the case to the shipping skid.
5. Lift case off of skid and into required position.

6. Level and square the case as needed by adjusting the leg leveler in each corner of base. (Use the wrench provided.) (The case must be level for proper drainage of defrost condensate to the condensate evaporator and allow for proper alignment of front glass.) The 50", 59", & 77" cases also have a set of leg levelers in the center. These must be adjusted until the bottom of the base is flat. Failure to adjust center leg could cause rear sliding doors to fall out of track.
7. The leveled case must be sealed to the floor using a NSF Listed Sealant.

### **Grill Removal (Refrigerated Units)**



**DANGER: Electric shock hazard. Do not operate unit with panels removed.**

There is a removable slotted panel at the rear of the case. The panel allows access to the condensing unit, the light ballast/ LED power supply, the condensate pan, and the field wiring connection box. Remove this panel to make field wiring connections. See electrical information and grounding section of this manual before wiring case.

Note: If electrical connection has been performed, disconnect power to case before removing grill panel.

1. Remove the rear grill panel screws from top of rear grill.
2. Tilt the top of rear grill panel outward as shown in illustration on the right.
3. Pull rear grill panel tabs up and out of slots in base of case.

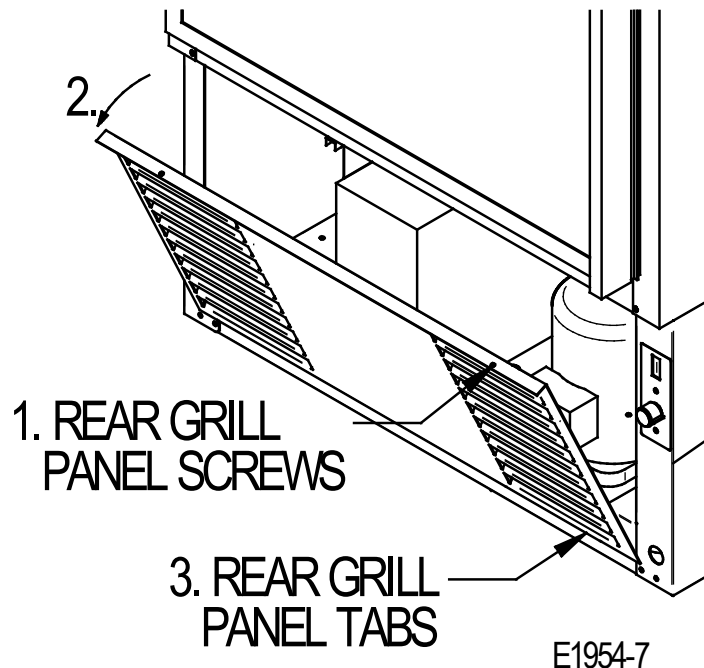

## **Condensate Evaporator (Refrigerated Units)**

This case is furnished with an electrical condensate evaporator. Plumbing connections are not required.

The condensate evaporator is located toward the front of the machine compartment and is accessible from the rear of the case. After removal of rear grill panel, make sure that the drain line has not been dislodged during shipment and that the drain trap is located properly over the water reservoir of the condensate evaporator pan.

## **Cleaning**

For initial setup, clean the case as outlined in the weekly cleaning section of this manual.

## **Refrigeration Installation (Refrigerated Units)**

### **Self Contained Models**

The self-contained models are shipped from the factory with a completely operational refrigeration system and require no modifications or adjustments upon installation.

---

# **ELECTRICAL INFORMATION & GROUNDING**

---

## **This Case Must Be Grounded**



**DANGER: Improper or faulty hookup of electrical components in the display case can result in severe injury or death.**

Only a licensed electrician must perform all case electrical connections.

All electrical wiring hookups must be done in accordance with all applicable local, regional, or national electrical standards.

A separate circuit for each display case is recommended to prevent other appliances on the same circuit from overloading the circuit and causing malfunction.

The electrical service must be grounded upon installation.

Optional Permanent Connected Models,

If this unit is designed for permanent connection to a power source. See the electrical data plate located at the rear of the case for proper circuit size and wire ampacity.

The electrical connection box is accessible from the rear of the case. Remove rear grill on refrigerated models. (See “Grill Removal” in the installation section of this manual.) See diagram below for location of the field wiring connection box.



---

---

# OPERATING INSTRUCTIONS

---

---

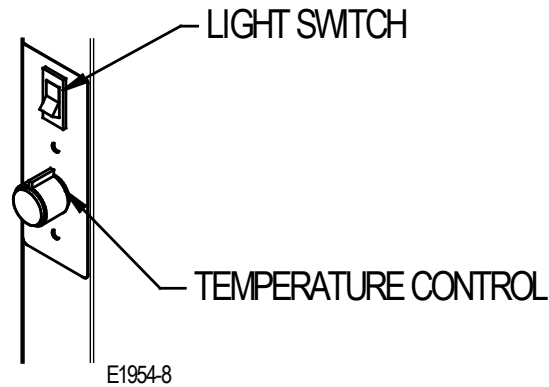

## **Controls (Refrigerated Units)**

### ***Light Switch***

This switch controls the power to the lighting circuit. The switch rocker is red in the “on” position, black in the “off” position.

### ***Temperature Control***

This controls the refrigerated side by cycling the compressor/condensing unit. It has an “off” position and the coldest setting when the knob is set all the way in the clockwise position. Set this control at the lowest setting possible, while maintaining desired case temperature.

## **Controls (Non-Refrigerated Units)**

### ***Power Switch***

This switch controls the power to the lighting circuit and to the optional interior fan if supplied. The switch rocker is red in the “on” position and black in the “off” position.

## **Shelves**

Each display is furnished with shelves that are adjustable up and down and can be tilted in three angular positions. See “Shelving Installation & Removal” section of this manual for proper installation, adjustment and removal of shelving.

## **Sliding Rear Doors**

The doors can be easily removed by lifting doors upward until the bottom edge of door clears the lower track. Swing the bottom of door outward and down out of top track.

Clean the door track frequently for easy door operation. A Very light film of lubricant, such as PAM, will help the doors slide easily.

On 59” and 77” models: If rear doors are falling out of track adjust the base center leg lever located under rear of base taller. If rear doors are difficult to remove from track adjust leg leveler shorter.

## **Placing Product into Case**

After completing shelving installation as outlined in “Shelving Installation and Removal” section of this manual you may begin placing product into the display case.

- Do not exceed 150 pounds of weight per shelf. Heavy product should be distributed evenly across the entire shelving area.
- Determine desired shelving location and angle before placing product in case. Product must be removed to readjust shelf location and angle.

### **(Refrigerated Models)**

- Do not overhang the front of wire shelves with product. Product may overhang rear of shelf, but allow a minimum of 1-1/2” between product and rear door. Improper clearance in front and rear of shelf will block the refrigerated airflow and could cause product loss.
- Do not block the slots along the front or rear of the case display pan. Covering these slots will block the refrigerated airflow and could cause product loss.
- The display pan is removable for cleaning and can become dislodged in shipment. To ensure proper airflow and performance of the case, make sure that the display pan is pushed completely down into evaporation tub. Check that the pan is installed properly before placing product the display pans.
- Allow refrigerated models to run for at least two hours before placing pre-chilled product into unit. Turn temperature control to the lowest possible position that maintains required interior cabinet temperature.

**-CASE SHOULD BE STOCKED WITH PRE-CHILLED PRODUCT ONLY.**

### **ATTENTION:**

**- Refrigerated display cases are designed to operate in a maximum environment of 75 DEG. F and 55% relative humidity. Exceeding these limits could cause poor case performance and sweating of glass panels.**

---

---

# **SHELVING INSTALLATION & REMOVAL**

---

---

1. Turn the light switch to the off position, on units with sliding rear doors, remove both rear doors from track by lifting doors upward until the bottom edge of door clears the lower track. Swing the bottom of door outward and down out of top track.
2. Insert a shelf bracket in the desired shelf standard slot on one side of case. The short set of shelf brackets are for the top shelf and the longer shelf brackets are for the middle and bottom shelves. Follow the instruction in the illustration below. Place an additional shelf bracket in the same shelf standard slot on the opposite end of case. Repeat for additional shelf tiers.

## INSTALLATION

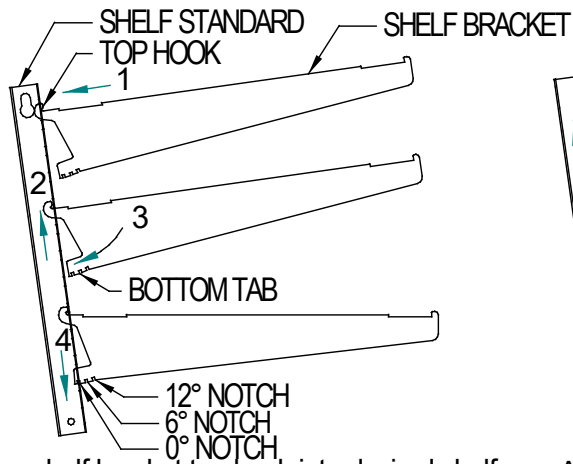

- Place shelf bracket top hook into desired shelf standard slot.
- Lift shelf bracket top hook to allow shelf bracket bottom tab to clear shelf standard slot.
- Swing shelf bracket bottom tab into shelf standard slot.
- Place the desired shelf bracket notch of 0, 6, or 12 degrees onto bottom of shelf standard slot.

## REMOVAL

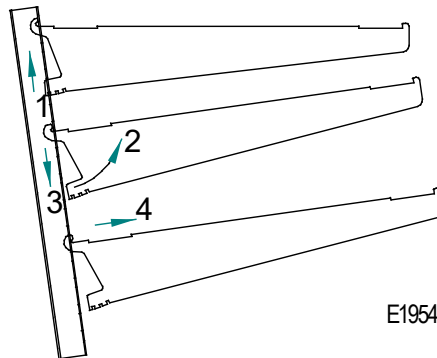

E1954-3

- Lift shelf bracket up to allow shelf bracket notch to clear the bottom of shelf standard slot.
- Swing shelf bracket bottom tab out of shelf standard slot.
- Drop shelf bracket down to allow shelf bracket top hook to clear top of shelf standard slot.
- remove shelf bracket top from shelf standard slot.

- Hang one end of shelf light assembly on the front notch of a shelf bracket with the light facing the rear of case and then the other end of shelf light assembly on the notch of the shelf bracket on the opposite end. Repeat for each additional shelf tiers
- Push shelf light cords into clear plastic clip located on inside of shelf brackets.
- Remove the cap from the appropriate female light sockets. If socket is not being used for a shelf light, the cap must be plugged into socket for entire light system to operate. NOTE: Grip each side of cap firmly and wiggle and pull cap straight out of socket. Do not roll cap during removal.

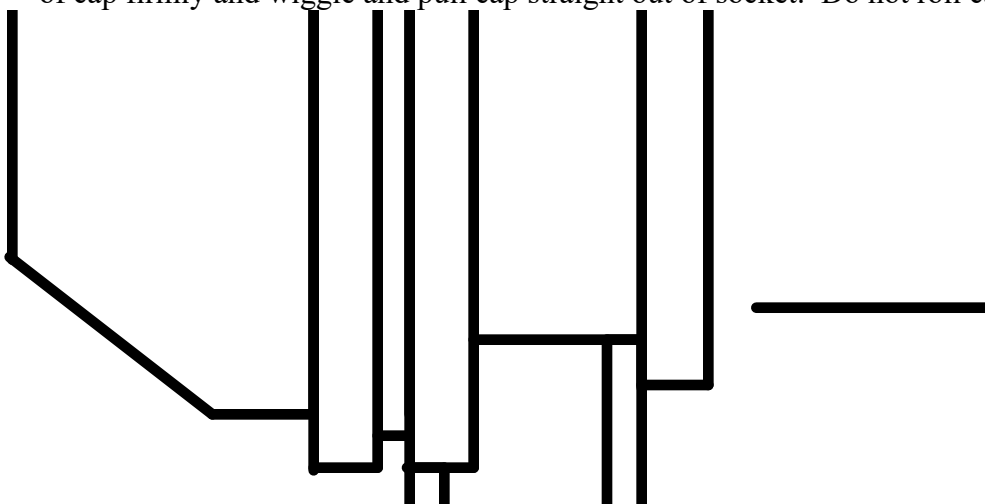

- Plug in each shelf light by aligning the male pins on the appropriate shelf light cord plugs with the female light sockets and push together. NOTE: Do not roll plug during insertion.

7. Hang one end of the shelf support on to the rear notch of one shelf bracket and then on the rear notch of the shelf bracket on the opposite side. Repeat for additional shelf tiers.
8. Place supplied shelving onto shelf supports as outlined in the appropriate “Shelf Installation” section of this manual.
9. On units with sliding rear doors, re-install both rear doors by lifting top of door into top track and swinging bottom of door onto bottom track. Install door labeled “inner door” first on inner track and door labeled “outer door” second on outer track.

### **Shelves and shelf light quantity**

It is not required that all shelves and shelf lights supplied with each case are used. The quantity of shelves and shelf lights can be tailored to your specific needs. If the supplied quantity of shelves and shelf lights are not required, cap unused female socket located in interior of the case mullion with caps supplied. Failure to do so will prevent entire lighting system from operating.

---

---

## **SHELF INSTALLATION**

---

---

### **Wire Shelves**

1. The Bakery models are provided with 22” wire shelves for the bottom and middle shelf and the 16” wire shelf is for the top shelf.
2. With rear sliding doors removed place front of wire shelf onto front shelf light and snap the front of shelf into the clear plastic clips on front light housing.
3. Snap the rear of shelf into the clear plastic clips on rear shelf support.
4. Repeat 2 & 3 for each tier.

NOTE: Units with 73” long rear shelf supports uses (2) wire shelves per tier. All other units use (1) wire shelf per tier.

### **Metal Shelves**

1. The Deli models are provided with a single metal shelf.
2. With rear sliding door removed, or rear swing door open, place front of metal shelf on to front shelf light.
3. Set the rear of the metal shelf on to the rear shelf support so that the notch at each end of metal shelf straddles the rear shelf support. If clear plastic clips were factory-installed on top of rear shelf support or front shelf light, remove and discard clear plastic clips.
4. Repeat steps 2 & 3 for each tier if supplied with more than (1) tier of shelving.

---

---

# MAINTENANCE

---

---

## Fluorescent Shelf Light Bulb Replacement (Before 1/2019)

1. All shelf light fixtures use a spring-loaded socket at one end. To remove the bulb push the bulb towards the spring-loaded socket until the opposite ends drops out of the socket.
2. The bulb is inside a clear shatter proof tube with a black plastic cap on each end. Be careful not to allow bulb to slide out of shatter proof tube.
3. Reinstall new bulb in to the existing shatter proof tube and reuse black plastic end caps. Reinstall bulb assembly in the same manner as described in the Bulb Removal Procedure. Be sure bulb is secure in bulb receptacles

**Note: Be sure to use a direct equivalent to the original bulb.**

## Fluorescent Top Light Bulb Replacement (Before 1/2019)

1. On units with sliding rear doors, remove both rear doors from track by lifting doors upward until the bottom edge of door clears the lower track. Swing the bottom of door outward and down out of top track. On units with rear swing doors completely open doors to allow access to interior of case.
2. Remove all shelves, shelf supports and Shelf lights from unit through rear door opening. (See “Shelving Installation and Removal” section of this manual for instruction if needed)
3. Remove top light lens clip screw(s), lens clip(s), and top light lens as illustrated below.
4. To remove bulb from top light housing, grip the bulb receptacle end caps at each end of bulb. Pull the bulb receptacle end caps straight outward toward front of case. Once bulb and bulb receptacle end caps are removed from top light housing remove the bulb receptacle end caps from end of bulb. (Note: 50” dual zone models do not have end caps.)
5. Reinstall new bulb in the same manner as described in the Bulb Removal Procedure. Be sure bulb is secure in bulb receptacles. **Note: Be sure to use a direct equivalent to the original bulb.**
6. Reinstall top light lens, lens clips, and lens clip screws in reverse order as shown in illustration below.

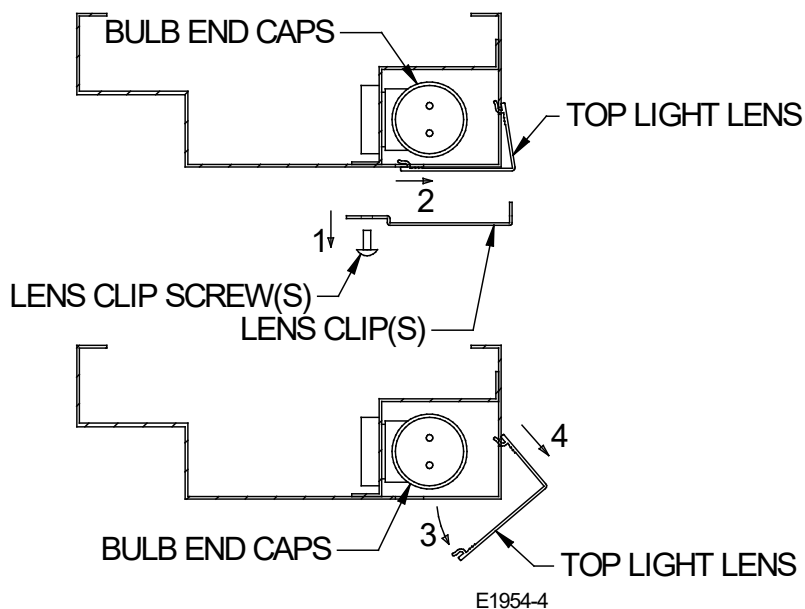

## LED Shelf Light Replacement (After 1/2019)

1. On units with sliding rear doors, remove both rear doors from track by lifting doors upward until the bottom edge of door clears the lower track. Swing the bottom of door outward and down out of top track. On units with rear swing doors completely open doors to allow access to interior of case.
2. Remove shelving from unit through rear door opening.
3. Unplug appropriate light housing cord from socket and remove shelf light assembly from unit through rear door opening.
4. Unplug the shelf light cord from the LED light. Starting at the end opposite the light cord, insert a putty knife or flat bladed screw driver between the shelf support and the LED light. This needs to be done to detach the double-sided tape that holds the LED light to the front shelf support.
5. Remove all double-sided tape residue from shelf support. Clean the backside of the new LED light and the mounting surface on the shelf support with isopropyl alcohol and allow to dry, before applying new double side tape to the back of the LED light. The LED light will be positioned between the two .094" holes on the shelf support, with each end of the light on the edge of the hole leaving both holes completely visible.

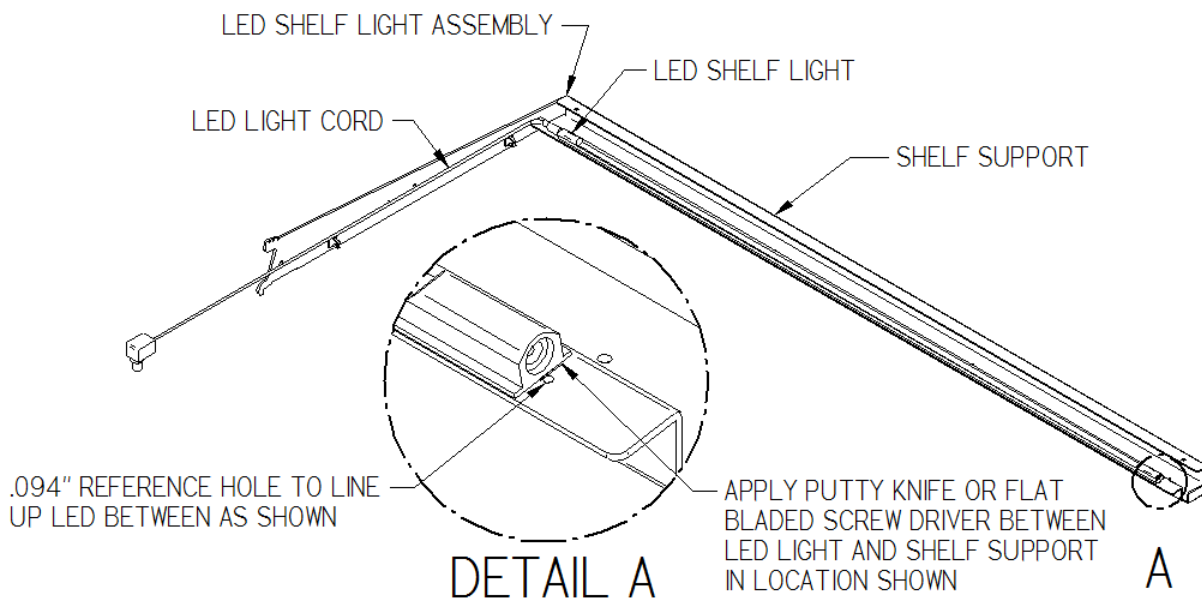

## LED Top Light Replacement (After 1/2019)

1. On units with sliding rear doors, remove both rear doors from track by lifting doors upward until the bottom edge of door clears the lower track. Swing the bottom of door outward and down out of top track. On units with rear swing doors completely open doors to allow access to interior of case.
2. Remove all shelves, shelf supports and Shelf light assemblies from unit through rear door opening. (See “Shelving Installation and Removal” section of this manual for instruction if needed)
3. Unplug top light cord from top light.
4. To remove the LED light from the light clips that are mounted to the bottom of the top glass support, push the light in line with the mounting surface on the light clip then rotate the LED towards the front of the case.
5. Reinstall new LED in the same manner as described in the LED Removal Procedure. Be sure that LED is secure in light clips. **Note: Be sure to use a direct equivalent to the original LED.** Plug the top light cord into the new LED top light.

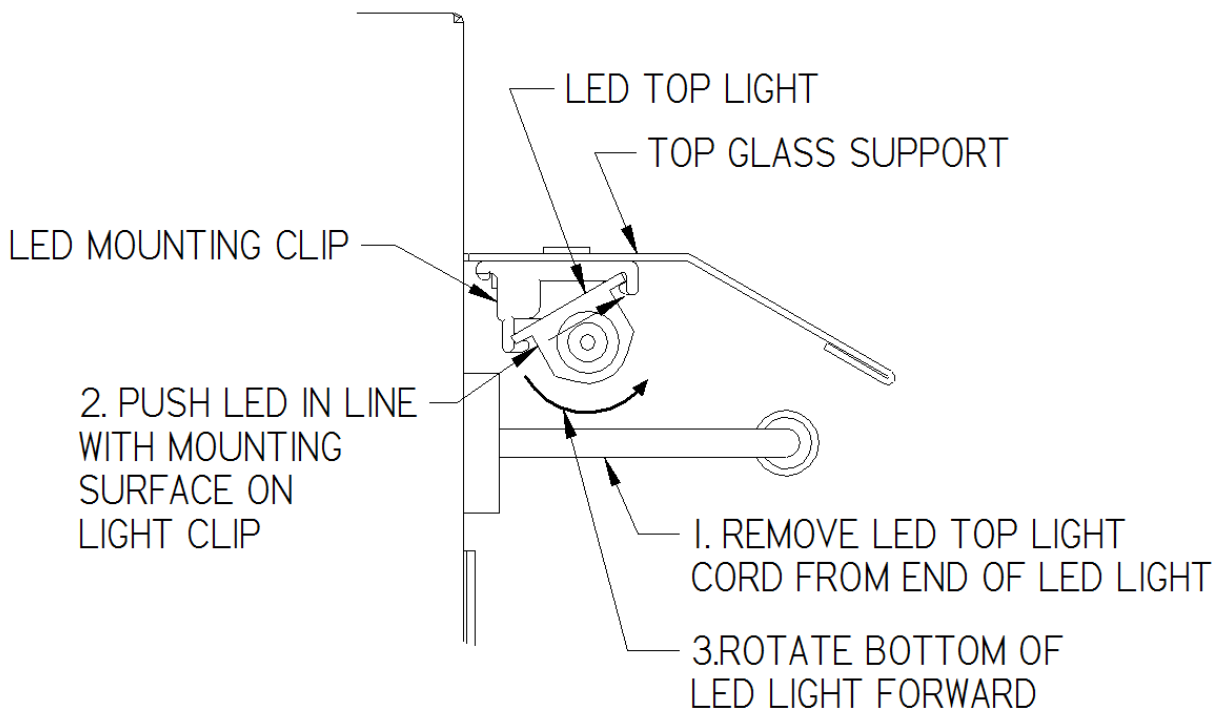



---

---

# PERIODIC MAINTENANCE

---

---

## Cleaning Condenser Coil



It is very important that the Condenser coil is cleaned twice per month to insure proper refrigeration performance and to prevent compressor failure. Failure to clean condenser coil will void condenser warranty.

1. Disconnect power to the unit.
2. Remove the back base panel located on the back bottom of unit by removing the panel retaining screws.
3. Carefully vacuum the front surface of condenser coil. Take care not to bend coil fins with vacuum cleaner nozzle.
4. Reinstall back panel and retaining screws.

---

---

# CLEANING INSTRUCTIONS

---

---

## Daily Cleaning

The case should be cleaned thoroughly, as described in the weekly cleaning section, before it is used for the first time.



**NOTICE:** Avoid splashing or soaking any electrical components with water to prevent electrical damage to the case.



**NOTICE:** Shut off lights and power switches and remove all product from case. Allow sufficient time for the unit to reach room temperature before proceeding with cleaning.



**NOTICE:** Remove all product from case before proceeding with cleaning procedure.

Note: For major spills or foreign material buildup use complete weekly cleaning instructions.

1. Clean all foreign materials from the door opening.
2. Wipe complete interior of case using a damp cloth.
3. Tilt the front glass forward as described in the illustrations below. This will allow easier access to clean interior front and side glass. The glass can then be cleaned with common window cleaners.



4. The remaining exterior surface should be wiped down using any soapy warm water.

Note: Do not use detergents or chlorine and do not use abrasive cleaners or pads to prevent scratching of surfaces.

## Weekly Cleaning

This procedure is recommended on a weekly basis. It may need to be performed more often if necessary to maintain a clean, sanitary case. The case should be cleaned to this procedure before using the first time.



**NOTICE:** Avoid splashing or soaking any electrical components with water to prevent electrical damage to the case.



**NOTICE:** Shut off light and power switches and remove all product from case. Allow sufficient time for the unit to reach room temperature before proceeding with cleaning.

## Interior Cleaning

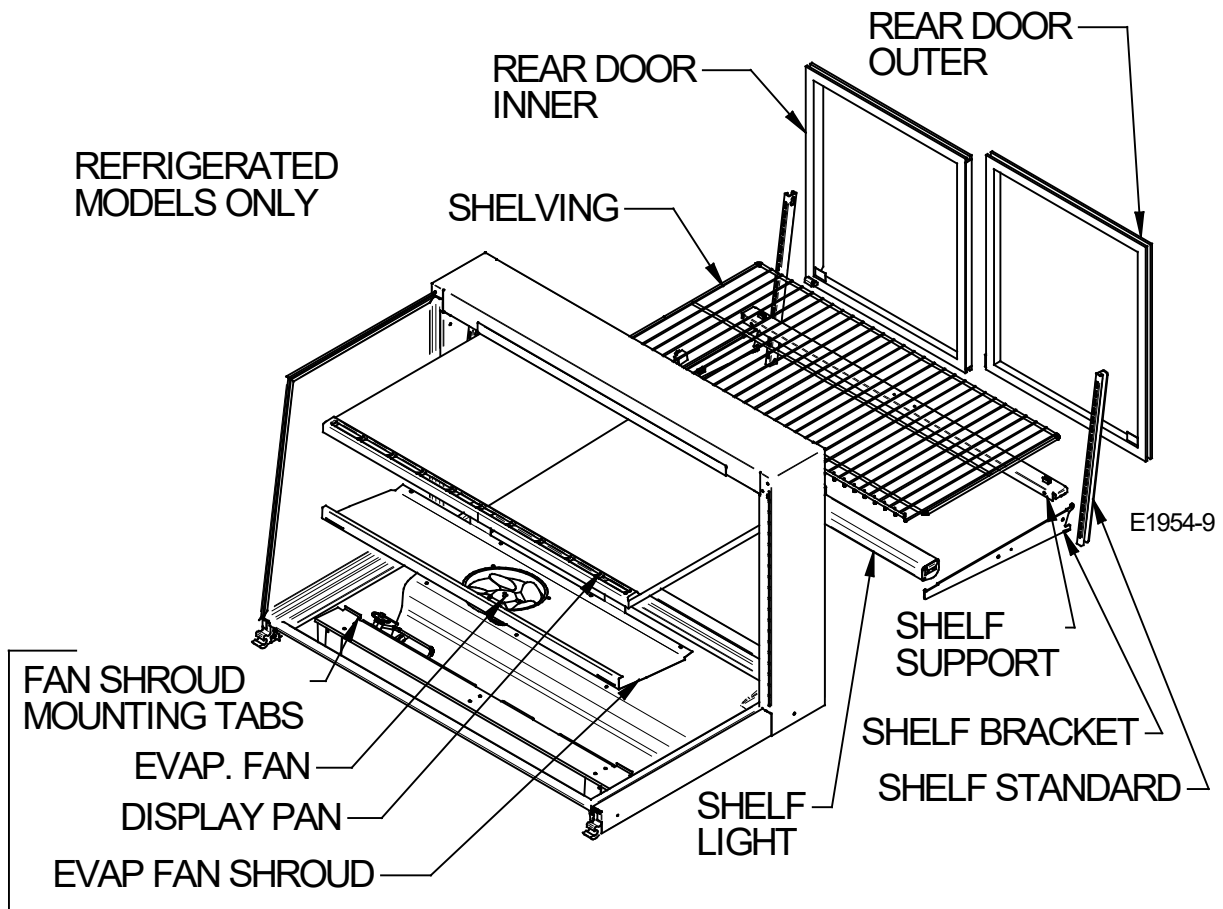

1. Remove all interior shelving as described in the shelving installation and removal section of this manual.
2. Remove both shelf standards from interior of case. First remove thumbscrew at bottom of shelf standard and then slide shelf standard up to allow top key slot to clear.

Steps 3 & 4 on refrigerated only.

3. Lift the display pan up and out of evaporator tub. Remove display pan through rear opening.
4. Remove the evaporator fan shroud. First remove the thumbscrews along the backside of evaporator fan shroud. Lift the rear of the evaporator fan shroud allowing the front to hinge on fan shroud mounting tabs. Reach in and unplug the evaporator fan motor cord. Continue to lift the evaporator fan shroud while at the same time pulling it to the door opening of case until the slots in the evaporator fan shroud can clear the fan shroud mounting tabs. Remove evaporator fan shroud through rear opening.
5. Clean the entire interior of the case using warm soapy water. Wipe off all soapy water with a damp cloth and allow to dry.

NOTE: Depending on the amount of usage and spillage of foreign material, some fasteners may have to be removed and parts disassembled to allow proper cleaning of the unit.

6. Clean all shelves, shelf support bars, shelf light assemblies, shelf brackets, and display pans using warm soapy water and a brush. Rinse thoroughly and allow to dry.
7. Clean all foreign material from inner and outer rear door tracks using warm soapy water and a brush. Apply a light film of lubricant such as PAM to make the doors operate smoother.
8. Clean both sides of the doors and interior of the front glass using any common window cleaner.

NOTE: Front glass can be tilted forward to simplify front glass cleaning. See “Daily Cleaning” section for glass tilting operation.

9. Reassemble the case in reverse order starting with Step 6.

## **Exterior Cleaning**

1. Clean the front glass using any common window cleaner.
2. The exterior surfaces should be wiped down using any ammoniated cleansers or warm soapy water.

NOTE: For major spills or foreign material build-up use complete weekly cleaning instruction.

---

---

# SERVICE INFORMATION

---

---

**CAUTION**  
RISK OF ELECTRIC SHOCK

DISCONNECT POWER  
BEFORE SERVICING UNIT

Before any service work is performed on the case, make sure all power is disconnected to the case.

Service problems or request for repair parts from authorized service agencies, trained service personnel, or owners should be referred to:

## Pre-Service Checklist

You may avoid the cost and inconvenience of an unnecessary service call by first reviewing this checklist of frequently encountered situations that can cause unsatisfactory case performance.



**CAUTION:** Before servicing case turn off power at the main breaker of fuse box.

## WARRANTY/TECHNICAL SERVICE DEPARTMENT

Federal Industries  
215 Federal Avenue  
Belleville, WI 53508

Toll Free: (800) 356-4206 / WI Phone (608) 424-3331

Fax: (608) 424-3234

## **Pre-Service Checklist**

### ***Case Does Not Operate***

Check for disconnected power supply.

Check for tripped breaker or blown fuse.

Check that the thermostat is not “off”.

### ***Lights Do Not Operate***

Check that light switch is on.

Be sure light is properly seated in the sockets.

Check that light cord(s) are tight in the sockets.

Plug unused light sockets with socket cap provided with socket.

### ***Case Temperature Too Warm***

Check that the cold air inlet and outlet slots are not blocked.

Be sure that the rear doors are closed and tightly sealed.

Check for a blocked or dirty condenser coil filter or condenser coil fins.

Check cold airflow. Lack of adequate cold airflow could be a defective evaporator fan or blocked evaporator coil. Check that paper or foreign material is not blocking evaporator. If the evaporator coil is blocked due to excessive frost, turn the thermostat knob to the “off” position for approximately one hour to defrost. Excessive frost will buildup if the case is operated with the door open or ajar.

Check that the display pans are installed properly.

### ***Glass Fogging***

Check room ambient – Case is designed to operate in an environment not to exceed 75°F and 55% relative humidity.

Check case temperature – Case is designed to operate between 38°F and 42°F.

Check that nothing is placed on the top of the case glass.

## **Special Service Situations**

There are rare occasions when the refrigerant charge must be evacuated from a case in order to perform service work. In those situations the refrigerant charge must be evacuated into a recovery system to prevent the possibility of hydrofluorocarbons (HFC's) from being released into the atmosphere.

If moisture or liquid is observed around or under case, an immediate investigation should be made by qualified personnel to determine the source of the moisture or liquid. The investigation made should determine if the case is malfunctioning or if there is a simple housekeeping problem.

Moisture or liquid around or under a case is a potential slip/fall hazard for persons walking by or working in the general area of the case. Any case malfunction or housekeeping problem that creates a slip/fall hazard around or under a case should be corrected immediately.

---

---

# **SALE & DISPOSAL**

---

---

## **Owner Responsibility**

If you sell or give away your Master-Bilt case you must make sure that all safety labels and the Installation-Service Manual are included with it. If you need replacement labels or manuals, Master-Bilt will provide them free of charge. Contact the technical service department at Master-Bilt at (800) 684-8988.

The technical service department at Master-Bilt should be contacted at the time of sale or disposal of your case so records may be kept of its new location.

If you sell or give away your Master-Bilt case and you evacuate the refrigerant charge before shipment. Master-Bilt recommends that the charge be evacuated into a recovery system to prevent the possibility of HFC's from being released into the atmosphere.

# REFRIGERATION & ELECTRICAL DATA

REFRIGERATION & ELECTRICAL DATA	REFRIGERANT	LIGHTS	EVAPORATOR	CONDENSATE	COMPRESSOR		TOTAL AMPS
	R134A BEFORE 1/20 / R513 AFTER 1/20		FAN MOTOR	PAN HEATER	RLA	LRA	
<b>NON REFRIGERATED</b>							
ECGD50	N/A	0.7	N/A	N/A	N/A	N/A	1.5
ECGD59	N/A	0.9	N/A	N/A	N/A	N/A	1.5
ECGD77	N/A	1.3	N/A	N/A	N/A	N/A	1.5
<b>REFRIGERATED SELF CONTAINED</b>							
ECGR50	24 / 23	0.7	0.4	1.2	8.8	58.8	10.5
ECGR59	26 / 25	0.9	0.4	1.2	8.8	58.8	11.6
ECGR77	30 / 29	1.3	0.8	1.2	10.1	68	14.2
ECGR50CD	24 / 23	0.7	0.4	1.2	8.8	58.8	10.5
ECGR59CD	26 / 25	0.9	0.4	1.2	8.8	58.8	11.6
ECGR77CD	30 / 29	1.3	0.8	1.2	10.1	68	14.2
Refer to the data plate attached to rear of the case for maximum fuse size and minimum circuit ampacity.							



# MAIN WIRING DIAGRAMS

ECGD MODELS ALL

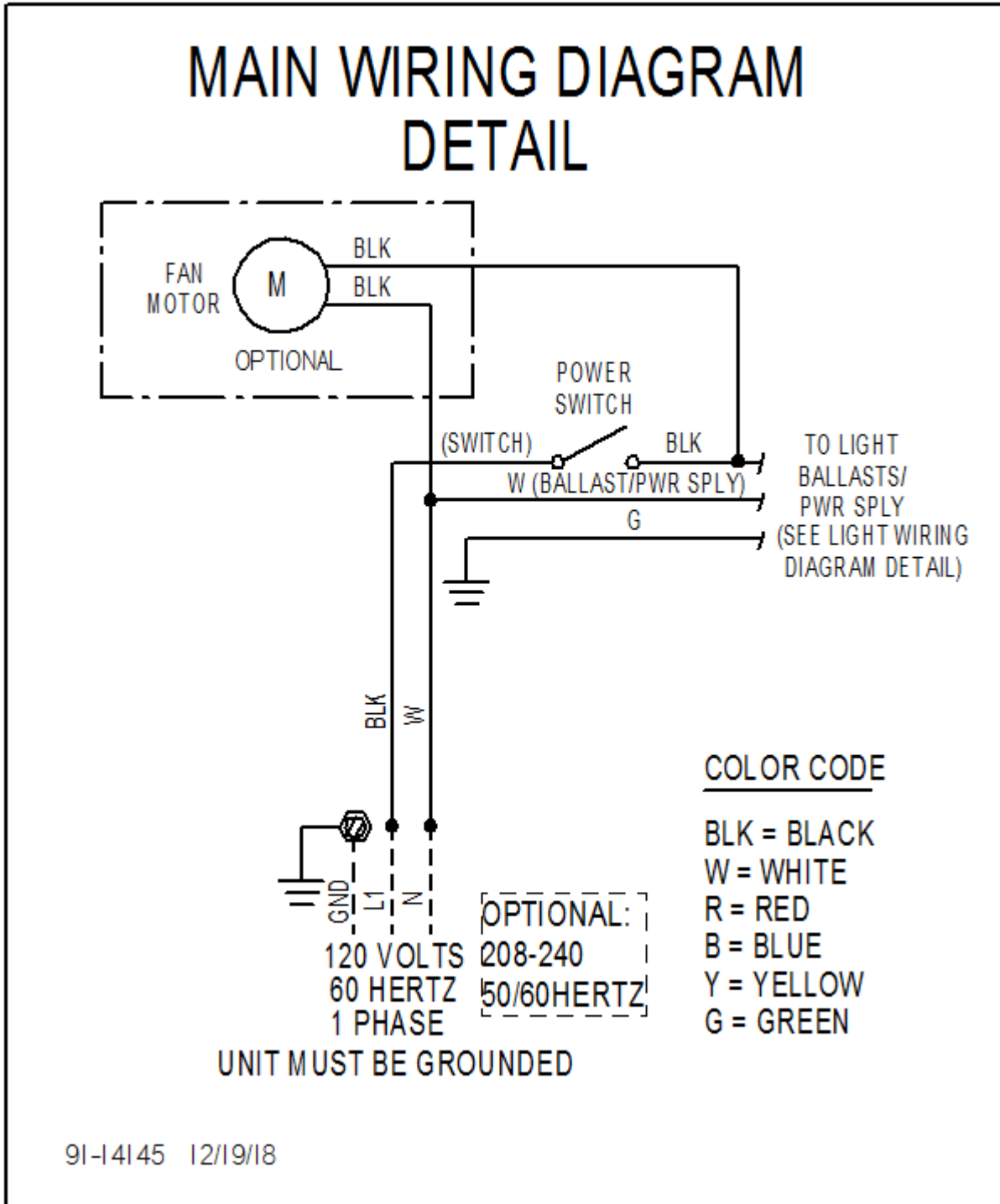

**ECGR MODELS ALL 120 VOLT REFRIGERATED SELF CONTAINED**

# MAIN WIRING DIAGRAM DETAIL

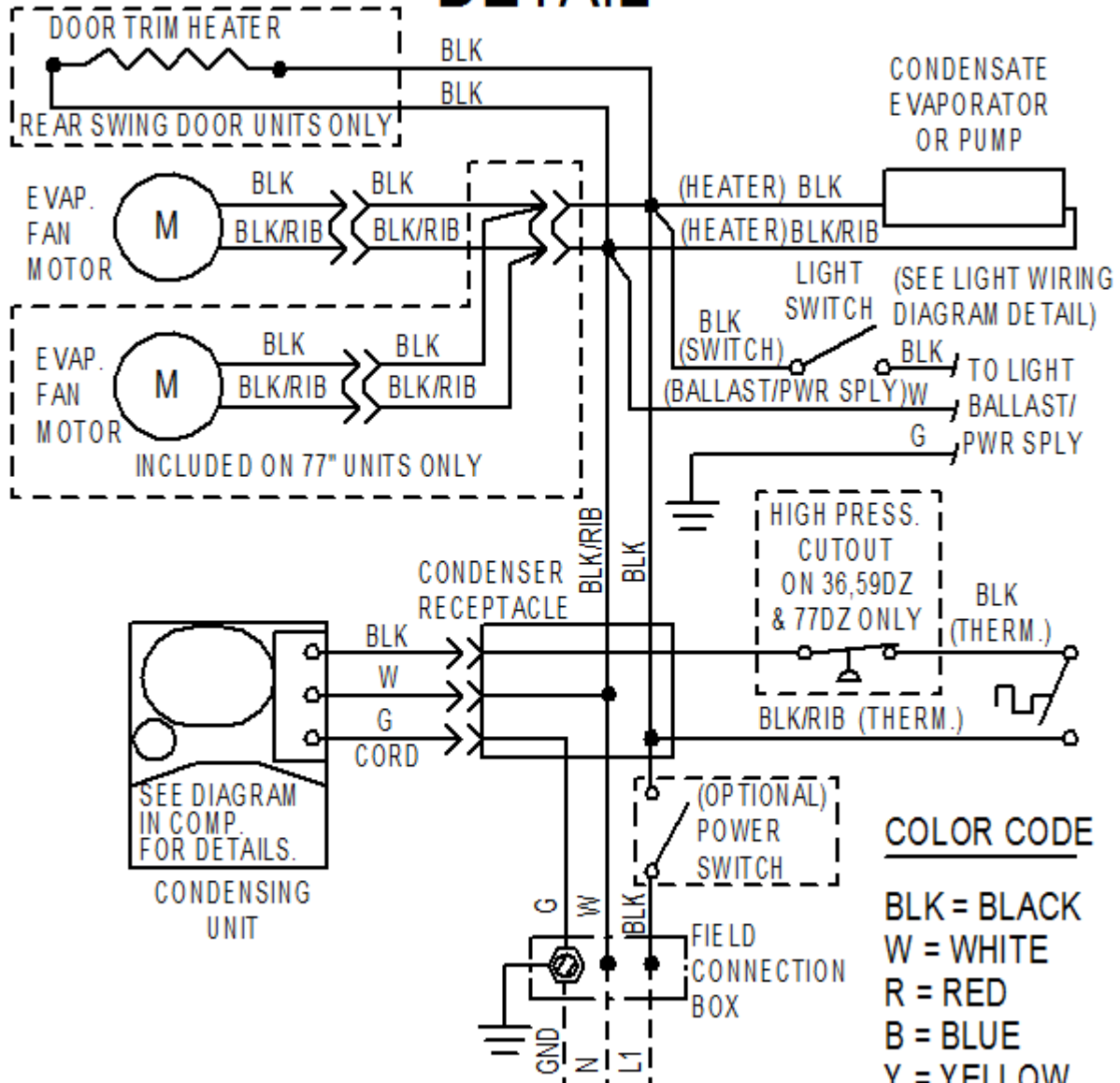

**COLOR CODE**

- BLK = BLACK
- W = WHITE
- R = RED
- B = BLUE
- Y = YELLOW
- G = GREEN

91-14146 10/22/18

# FLUORESCENT LIGHT WIRING DIAGRAMS BEFORE 1/2019

FLUORESCENT BEFORE 1/2019  
ECGR50CD, ECGR59CD, ECGR77CD

## LIGHT WIRING DIAGRAM DETAIL

(2) F017T8, FO25T8, FO32T8, FO40T8

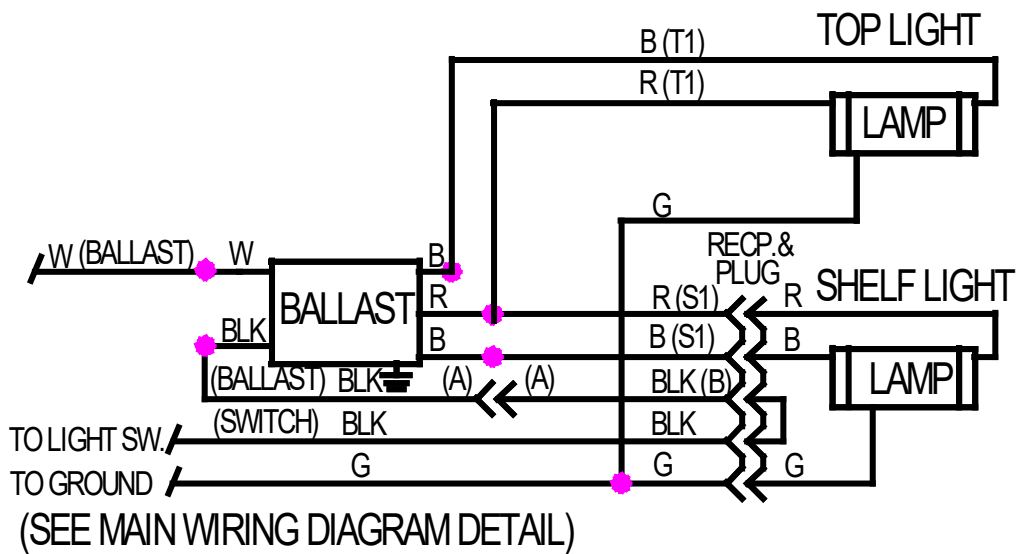

COLOR CODE:

BLK = BLACK

W = WHITE

R = RED

B = BLUE

Y = YELLOW

G = GREEN

91-13924 04/16/01

**FLUORESCENT BEFORE 1/2019**  
**ECGR50, ECGR59 and ECGD50, ECGD59**

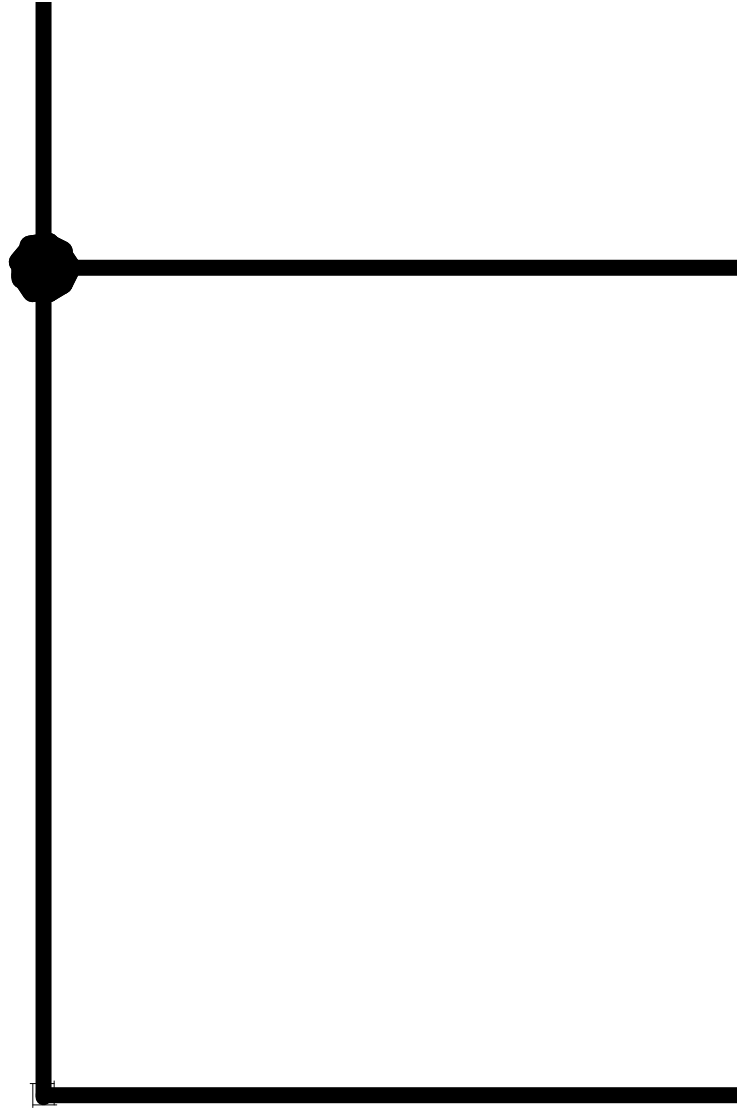

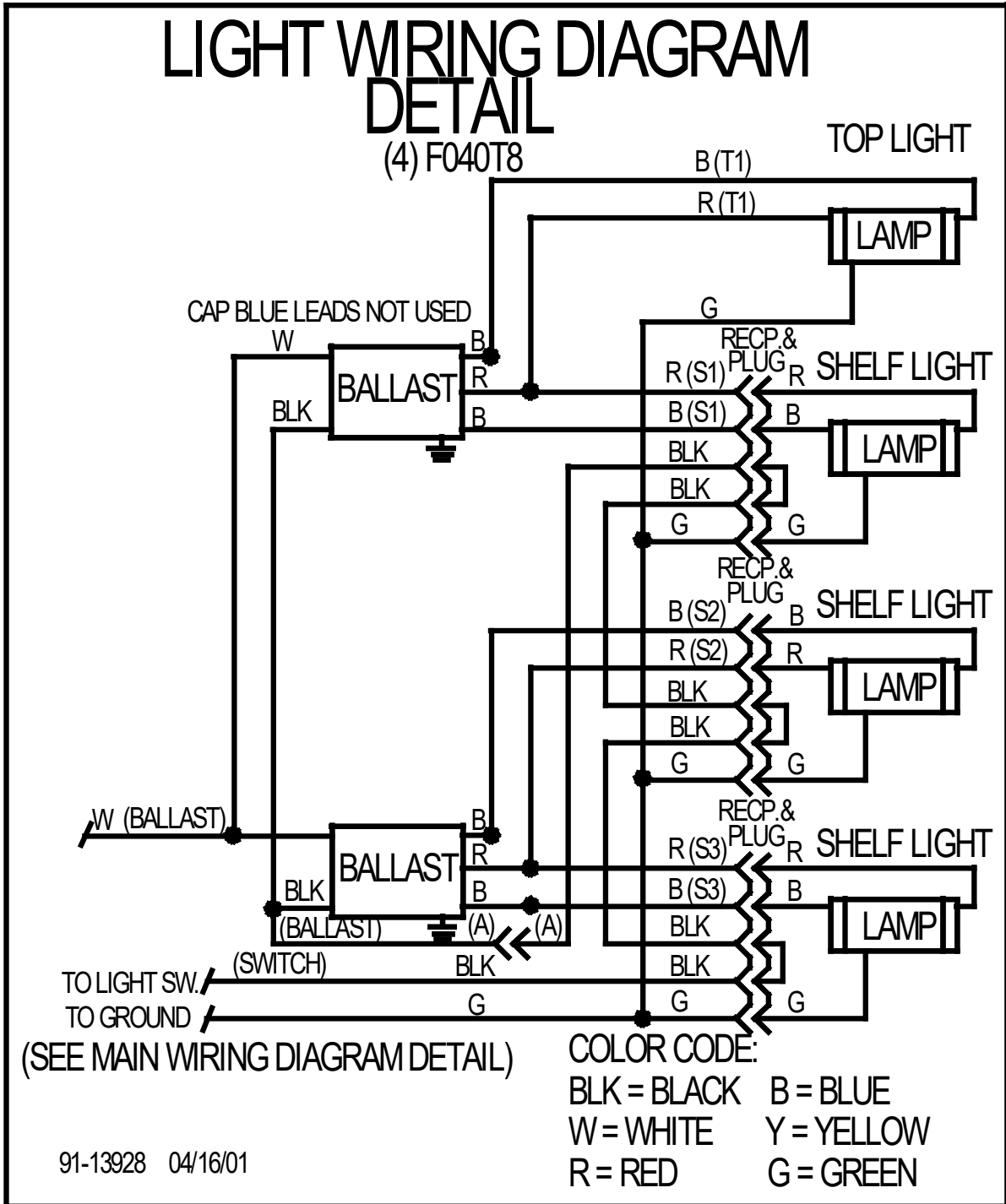

# LED LIGHT WIRING DIAGRAM AFTER 1/2019

All models with standard LED shelf lights

## LIGHT WIRING DIAGRAM DETAIL

TYPICAL: SHELF LIGHT  
QUANTITY MAY VARY

DZ CASES USE (2)  
DUPLICATE LIGHT  
CIRCUITS AS SHOWN

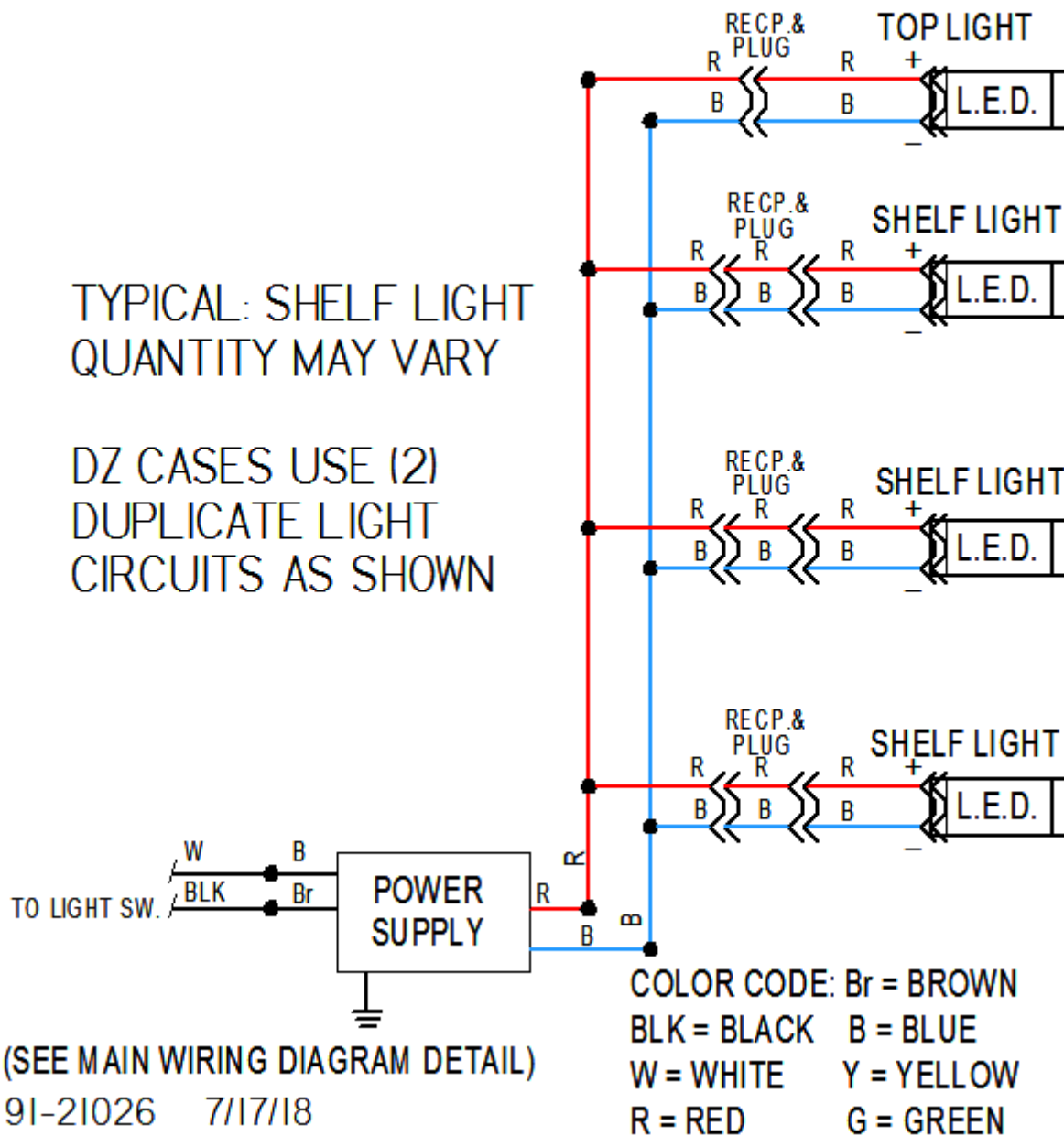

(SEE MAIN WIRING DIAGRAM DETAIL)

91-21026 7/17/18

# REPLACEMENT PARTS

## FLUORESCENT LIGHT ELECTRICAL COMPONENTS BEFORE 1/2019

MODELS	LIGHT SWITCH	LIGHT BALLAST	LIGHT BULB	LIGHT BULB CAP	SHELF LIGHT CORD	SHELF LIGHT RECEPT. HARNESSES	SHELF LIGHT LENS	TOP LIGHT WIRE HARNESSES	TOP LIGHT LENS	LIGHT WIRING DIAGRAM	SC MAIN WIRING DIAGRAM
<b>ECGR50</b>	41-11066	39-12904	42-11069	42-15441	43-15888	43-13920	42-14141	43-15889	42-13643	91-13927	91-14146
<b>ECGR50C D</b>	41-11066	39-12902	42-11069	42-15441	43-15888	43-13922	42-14141	43-15889	42-13643	91-13924	91-14146
<b>ECGD50</b>	41-11066	39-12904	42-11069	42-15441	43-15888	43-13920	42-14141	43-15889	42-13643	91-13927	91-14145
<b>ECGR59</b>	41-11066	39-12904	42-11070	42-15441	43-15888	43-13920	42-14142	43-15889	42-13644	91-13927	91-14146
<b>ECGR59C D</b>	41-11066	39-12902	42-11070	42-15441	43-15888	43-13922	42-14142	43-15889	42-13644	91-13924	91-14146
<b>ECGD59</b>	41-11066	39-12902	42-11070	42-15441	43-15888	43-13922	42-14142	43-15889	42-13644	91-13927	91-14145
<b>ECGR77</b>	41-11066	39-12903	42-11071	42-15441	43-15888	43-13920	42-14164	43-15889	42-13645	91-13928	91-14146
<b>ECGR77C D</b>	41-11066	39-12903	42-11071	42-15441	43-15888	43-13922	42-14164	43-15889	42-13645	91-13924	91-14146
<b>ECGD77</b>	41-11066	39-12903	42-11071	42-15441	43-15888	43-13922	42-14164	43-15889	42-13645	91-13928	91-14145

## LED LIGHT ELECTRICAL COMPONENTS AFTER 1/2019

MODELS	LIGHT SWITCH	LED POWER SUPPLY	LED LIGHT	TOP LIGHT CORD	SHELF LIGHT CORD	SHELF LIGHT CORD CLIP	30° LED LIGHT CLIP	SHELF LIGHT RECEPTACLE HARNESSES	TOP & SHELF LIGHT WIRE HARNESSES	LIGHT WIRING DIAGRAM	SC MAIN WIRING DIAGRAM
<b>ECGR50</b>	41-11066	39-20986	42-20871-42C30	43-20860-1W	43-20862-6W	67-20952	67-20869-30	43-20996-W	43-21005	91-21026	91-14146
<b>ECGR50C D</b>	41-11066	39-20986	42-20871-42C30	43-20860-1W	43-20862-6W	67-20952	67-20869-30	43-20996-W	43-21005	91-21026	91-14146
<b>ECGD50</b>	41-11066	39-20986	42-20871-42C30	43-20860-1W	43-20862-6W	67-20952	67-20869-30	43-20996-W	43-21005	91-21026	91-14145
<b>ECGR59</b>	41-11066	39-20986	42-20871-54C30	43-20860-1W	43-20862-6W	67-20952	67-20869-30	43-20996-W	43-21005	91-21026	91-14146
<b>ECGR59C D</b>	41-11066	39-20986	42-20871-54C30	43-20860-1W	43-20862-6W	67-20952	67-20869-30	43-20996-W	43-21005	91-21026	91-14146
<b>ECGD59</b>	41-11066	39-20986	42-20871-	43-20860-	43-20862-	67-20952	67-2086	43-20996-W	43-21005	91-21026	91-14145

			54C30	1W	6W		9-30				
<b>ECGR77</b>	41-11066	39-20555	42-20871-72C30	43-20860-1W	43-20862-6W	67-20952	67-20869-30	43-20996-W	43-21005	91-21026	91-14146
<b>ECGR77C D</b>	41-11066	39-20555	42-20871-72C30	43-20860-1W	43-20862-6W	67-20952	67-20869-30	43-20996-W	43-21005	91-21026	91-14146
<b>ECGD77</b>	41-11066	39-20555	42-20871-72C30	43-20860-1W	43-20862-6W	67-20952	67-20869-30	43-20996-W	43-21005	91-21026	91-14145

## GLASS COMPONENTS

MODELS	CURVED FRONT GLASS	END GLASS CLEAR	END GLASS REFL. L.H.	END GLASS REFL. R.H.	FRONT GLASS EDGE SEAL 3'
<b>ECGR50</b>	SA4846-3	50-18938	50-18938-L	50-18938-R	64-13122
<b>ECGR50C D</b>	SA4846-3	50-18938	50-18938-L	50-18938-R	64-13122
<b>ECGD50</b>	SA4907-3	91-19102	91-19102-L	91-19102-R	64-14182
<b>ECGR59</b>	SA4846-4	50-18938	50-18938-L	50-18938-R	64-13122
<b>ECGR59C D</b>	SA4846-4	50-18938	50-18938-L	50-18938-R	64-13122
<b>ECGD59</b>	SA4907-4	91-19102	91-19102-L	91-19102-R	64-14182
<b>ECGR77</b>	SA4846-5	50-18938	50-18938-L	50-18938-R	64-13122
<b>ECGR77C D</b>	SA4846-5	50-18938	50-18938-L	50-18938-R	64-13122
<b>ECGD77</b>	SA4907-5	91-19102	91-19102-L	91-19102-R	64-14182

## REFRIGERATION COMPONENTS

MODELS	CONDENSING UNIT (SC) 120V (SC) 240V		EVAPORATOR COIL	EXPANSION VALVE	EVAPORATOR FAN MOTOR W/BLADE	EVAPORATOR FAN BLADE	FILTER DRIER	THERMOSTAT	CONDENSATE PAN ASSY BEFORE 1/20 / AFTER 1/20	CONDENSATE HEATER BEFORE 1/20
<b>ECGR50</b>	30-14218	30-15328	33-13357	32-12625	41-13363	72-12254	32-12391	32-15495	SA-2134 / 40-20420	40-13362
<b>ECGR50C D</b>	30-14218	30-15328	33-13357	32-12625	41-13363	72-12254	32-12391	32-15495	SA-2134 / 40-20420	40-13362
<b>ECGR59</b>	30-14218	30-15328	33-13358	32-12625	41-13363	72-12254	32-12391	32-15495	SA-2134-1 / 40-20421	40-13362
<b>ECGR59C</b>	30-	30-15328	33-13358	32-12625	41-	72-12254	32-	32-	SA-2134-1	40-





**California Residents Only.**

**⚠ WARNING**

**This product can expose you to chemicals including chromium which is known to the State of California to cause cancer and birth defects or other reproductive harm. For more information go to [www.P65Warnings.ca.gov](http://www.P65Warnings.ca.gov)**