

E1621
Rev A 09-01-18



The Signature of Quality®

SQ3HD, SQ4HD, SQ6HD & SQ8HD

INSTALLATION & OPERATION INSTRUCTIONS



KEEP THIS MANUAL FOR FUTURE REFERENCE

Engineering and technical data are subject to change without notice.

Federal Industries
Toll Free 1(800) 356-4206

P.O. Box 290
WI Phone (608) 424-3331

Belleville, WI 53508
Fax: (608) 424-3234

Contents

INTRODUCTION	1
WARNING LABELS & SAFETY INSTRUCTIONS	2
PRE-INSTALLATION PROCEDURES.....	3
INSPECTION FOR SHIPPING DAMAGE	3
INSTALLATION INSTRUCTIONS	3
LOCATING THE DISPLAY CASE.....	3
REMOVING CASE FROM SHIPPING SKID	4
REMOVING PACKAGING MATERIAL.....	4
LEVELING THE CASE	4
GRILL REMOVAL.....	4
DRAIN	4
HUMIDITY SYSTEM.....	4-5
LIGHTS.....	5
ELECTRICAL INFORMATION & GROUNDING	5
OPERATING INSTRUCTIONS	6
INITIAL START-UP.....	6
DOORS	6
LIGHT REPLACEMENT	6
PLACING PRODUCT INTO CASE	6
HINGED FRONT GLASS.....	7
COMPUTER CONTROLS.....	8-10
CLEANING INSTRUCTIONS	11
DAILY CLEANING	11
WEEKLY CLEANING.....	11
INTERIOR CLEANING	12
EXTERIOR CLEANING	12
SERVICE INFORMATION.....	13
PRE-SERVICE CHECKLIST.....	13
SPECIAL SERVICE SITUATIONS.....	14
SALE & DISPOSAL	14
OWNER RESPONSIBILITY	14
ELECTRICAL DATA.....	15
REPLACEMENT PARTS	16-17
WIRING DIAGRAM – SQ3HD, SQ4HD, SQ6HD, & SQ8HD	18
WIRING DIAGRAM - RECEPTACLE.....	19

INTRODUCTION

Thank you for purchasing a Federal Industries display case. This manual contains important instructions for installing and servicing the Market Deli Refrigerated Cases. A repair parts list and wiring diagram are also included in the manual. Read all of these documents carefully before installing or servicing your case.



NOTICE

Read this manual before installing your case. Keep this manual and refer to it before doing any service on the equipment. Failure to do so could result in personal injury or damage to the case.



NOTICE

Installation and service of the electrical components in the case must be performed by a licensed electrician.

The portions of this manual covering electrical components contain technical instructions intended only for persons qualified to perform electrical work.



DANGER

Improper or faulty hookup of electrical components in the case can result in severe injury or death.

All electrical wiring hookups must be done in accordance with all applicable local, regional, or national standards.

SERIAL NUMBER

Record the model and serial numbers of the case for easy reference. Always refer to both model and serial numbers in your correspondence regarding the case.

Case Model _____ Serial Number _____
Condensing Unit Model _____ Serial Number _____

This manual cannot cover every installation, use, or service situation. If you need additional information, call or write us:

**Warranty/Technical Service Department
Federal Industries
P.O. Box 290
Belleville, WI 53508
Toll Free (800) 356-4206 / WI Phone (608) 424-3331**

WARNING LABELS & SAFETY INSTRUCTIONS



This is the safety-alert symbol. When you see this symbol on your case or in the manual, be alert to the potential for personal injury or damage to your equipment.

Be sure you understand all safety messages and always follow recommended precautions and safe operating practices.



NOTICE TO EMPLOYERS

You must make sure that everyone who installs, uses, or services your case is thoroughly familiar with all safety information and procedures.

Important safety information is presented in this section and throughout the manual. The following signal words are used in the warnings and safety messages:

DANGER: Severe injury or death will occur if you ignore the message.

WARNING: Severe injury or death can occur if you ignore the message.

CAUTION: Minor injury or damage to your case can occur if you ignore the message.

NOTICE: This is important installation, operation, or service information. If you ignore the message, you may damage your case.

The warning and safety labels shown throughout this manual are placed on your Federal Industries case at the factory. Follow all warning label instructions. If any warning or safety labels become lost or damaged, call our customer service department at 1(800) 356-4206 for replacements.

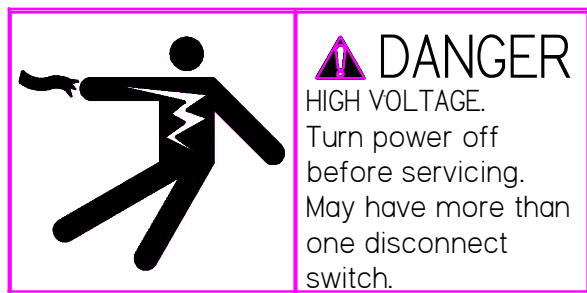

This label is located on the back of the display case.

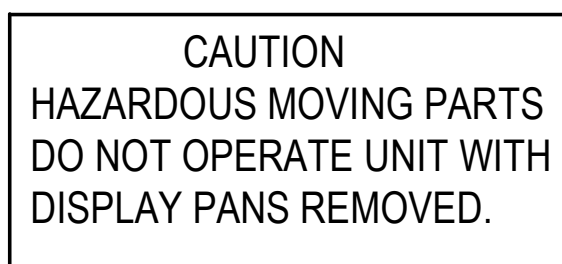

This label is located below the display pan.

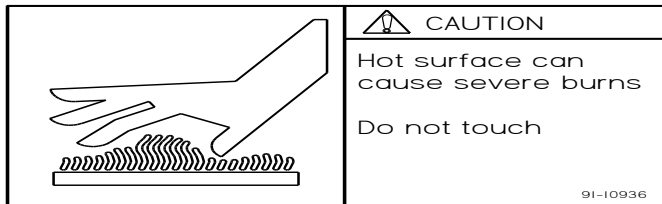

These lamps have been treated to resist breakage and must be replaced with a similarly treated 60w maximum lamp in standards.

91-13762

This label is located on the back of the display case.

PRE-INSTALLATION PROCEDURES

Inspection For Shipping Damage

You are responsible for filing all freight claims with the delivering truck line. Inspect all cartons and crates for damage as soon as they arrive. If damage is noted to shipping crates or cartons, or if a shortage is found, note this on the bill of lading (all copies) prior to signing.

If damage is discovered when the case is uncrated, immediately call the delivering truck line and follow-up the call with a written report indicating concealed damage to your shipment. Ask for an immediate inspection of your concealed damage item. Crating material must be retained to show the inspector from the truck line.

INSTALLATION INSTRUCTIONS

Locating The Display Case

The case should be located where it is not subjected to the direct rays of the sun, heating ducts, grills, radiator, or ceiling fans, nor should it be located near open doors or main door entrances. Also, avoid locations where there is excessive air movement or air disturbances.

Removing Case from Shipping Skid

CAUTION:



Do not push against the curved glass, end glass, doors, or doorframes when removing the case from the skid or moving the case. Case damage or glass breakage could result.

Move the case as near as possible to the final location before removing it from the shipping skid.

Remove the eight (8) screws that secure the case to the skid.

Removing Packaging Material

Remove the brackets that held the case to the shipping skid.

Remove the shipping tape that secures the doors and lift-up glass. If it is necessary to remove tape residue from plastic materials, use cleaning compounds recommended in the cleaning section of this manual.

Leveling the Case

The case must be level for proper drainage of the tub.

Four (4) leg levelers are provided for leveling the case. The leg levelers can be turned in, and the case can be placed with the base frame on the floor.

The leveled case **must** be sealed to the floor using and NSF Listed Sealant.

Grill Removal



DANGER: Electrical shock hazard. Do not operate unit with panels removed.

There is one (1) removable panel on the back of the case. The panel allows access to the field wiring connection box. Remove this panel to make field-wiring connections.

Drain

The case is supplied with a 1" male NPT drain fitting that can be used for a connection to a drain.

Humidity System

A water line must be connected to the unit in order for the automatic-fill humidity system to function. The water line has a 1/4" SAE flare fitting for connection to a water supply. A water filter is highly recommended to reduce lime deposits in water

reservoir and float switch mechanism. To reduce “hammering” of solenoid valve, needle valve can be adjusted to reduce incoming water pressure to solenoid. Needle valve is located at inlet of solenoid valve.

Lights

The lights are coated incandescent bulbs and must be replaced with exact equivalent bulbs. (60 Watt Maximum)

ELECTRICAL INFORMATION & GROUNDING

This Case Must Be Grounded



DANGER: Improper or faulty hookup of electrical components in the display case can result in severe injury or death.

All case electrical connections must be performed only by a licensed electrician.

All electrical wiring hookups must be done in accordance with all applicable local, regional, or national electrical standards.

A separate circuit for each display case is recommended to prevent other appliances on the same circuit from overloading the circuit and causing malfunction.

The electrical service must be grounded upon installation.

This unit is designed for permanent connection to a power source. See the electrical data plate located next to electrical junction box for proper circuit size and wire ampacity.

The electrical field connection 2 x 4 box is accessible from the rear of the case and is located in the right “leg” (as viewed from case rear). A second 2 x 4 field connection box is also located in the right leg and is required to supply electrical power to the general purpose receptacle.

OPERATING INSTRUCTIONS

Initial Start-Up

After all the checks outlined in the installation section of this manual have been made, the case is ready to be put into service.

Doors

Clean the door track frequently for easy door operation. A very light film of lubricant, such as PAM, will help the doors slide easily.

The entire door track assembly may be removed if desired by tilting the top back and lifting the entire frame out.

The display case is intended to be operated with the rear doors in place. However, during peak service periods, the doors may be removed for ease of serving out of case. DO NOT keep doors off unit for long periods of time. Temperature display may not read accurately with doors off of case. Disregard this temperature reading if doors have been off unit for extended periods.

Light Replacement

Light bulbs are removed by unscrewing counter clockwise. Install bulbs by screwing in clockwise. Do not over tighten.

When replacing lights, use direct equivalents to the original bulbs.

Placing Product into Case

Do not block the slots along the front or rear of the case display floor.

CASE SHOULD BE STOCKED WITH PRE-CHILLED PRODUCT ONLY.

All well cavities must be completely covered with food pans (not included) for proper operation of case. A variety of sizes of pans can be used from 2" to 6" in depth.

<u>Model</u>	<u># of Well Cavities</u>
SQ3HD	2
SQ4HD	3
SQ6HD	5
SQ8HD	7

Always preheat the wells before placing product into case. Freshly cooked product **should not** be placed into case with a probed temperature of less than 170°F.

The digital temperature display measures **air** temperature inside the case. This display is an indication only. The most accurate method to confirm satisfactory temperatures is to probe product inside the case.

Hinged Front Glass

DO NOT OPERATE GLASS UNTIL CASE REACHES ROOM TEMPERATURE.

The front glass hinges up for easy cleaning of the case interior. Pneumatic cylinders assist in lifting the glass. The glass will hold open in any position.

To close glass, push down on center of handle until glass rests on top of support clips. It may be necessary to lift glass slightly to push it onto clips.

To close glass, push down on center of handle until glass resets on top of support clips. It may be necessary to lift glass slightly to push it onto clips.

The hinged glass mechanism will give years of reliable operation in normal usage. Service on the lift mechanism is required if . . .

- The glass becomes difficult to open.
- The glass does not hold in the open position.
- The glass closes fast.

Consult the factory if service is required.

CAUTION:



Operation of lift-up glass is to be done by trained store personnel only. This case is not intended to be used as a self-serve unit. Do not allow customers to operate lift-up glass.

COMPUTER CONTROLS
for
SQHD CASES

E3015(2-Well) E3016(3-Well) E3017(5-Well) E3018 (7-Well)

- A. Display**
Display temperature readout and displays the time.
 - B. Down Arrow**
Press once to display current heat setting, press again to change to a cooler setting.
 - C. Up Arrow**
Press once to display current heat setting. Press again to change to a warmer setting.
- Temperature Setting**
The display has an off position, "0", and numbered position 1 through 9. The hottest setting is 9. Be using the up and down arrows, set the display at the lowest number necessary to achieve desired case temperature.
- D. Well Buttons**
Press to display current setting. Use up and down arrows to adjust.
 - E. Clock Display/Set**
Press to display current time. Adjust time with bottoms B (Hours) & C (Minutes). Press again to return the temperature display.
 - F. Start Time**
Press to display current auto start time – adjust same as clock.
 - G. Stop Time**
Press to display current auto stop time – adjust same as clock. If start and stop time are the same, auto start/stop is off.
 - H. Light Switch**
Turns lights on and off. Red light indicates on.
 - I. Overhead Warmer Buttons**
Press to display current setting. Use up and down arrows to adjust.
 - J. Humidity Switch**
Turns the humidification system on and off. Red light indicates switch is on.
 - K. Power Switch**
Turns off power to all components – retains all settings. This **does not** turn off complete power to the unit.

E3015

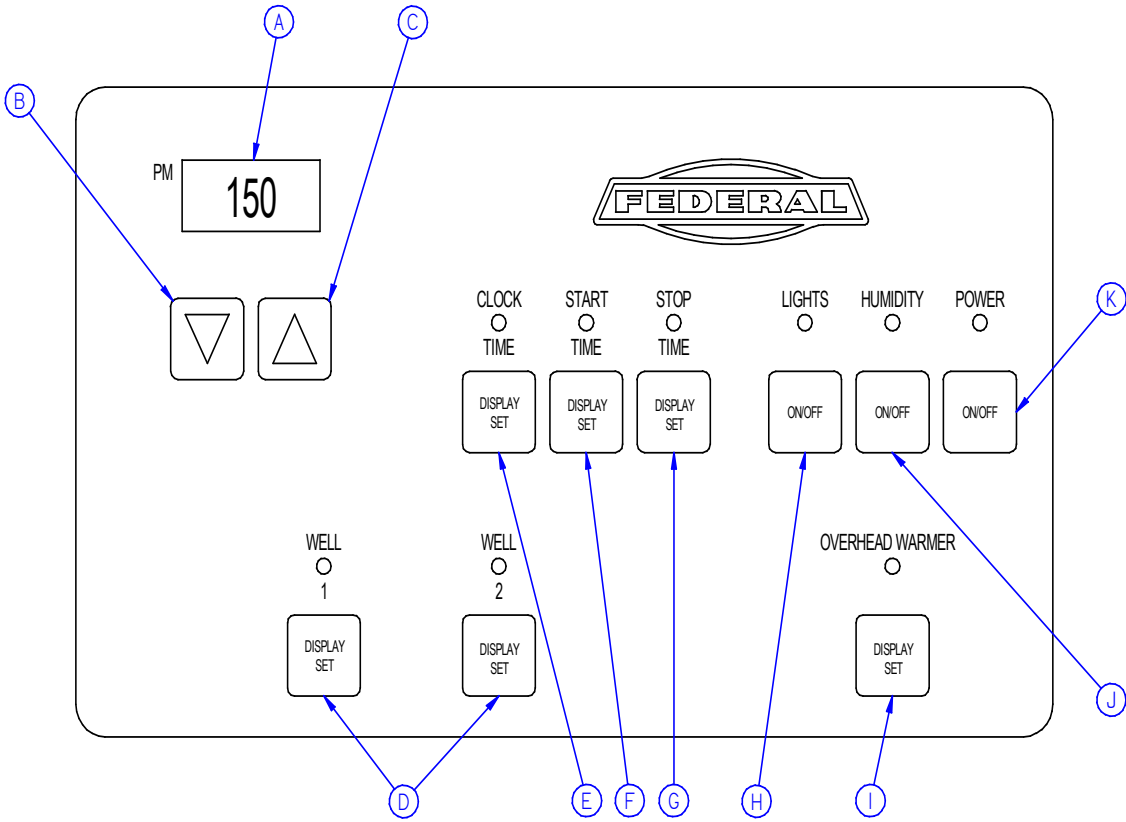

E3016

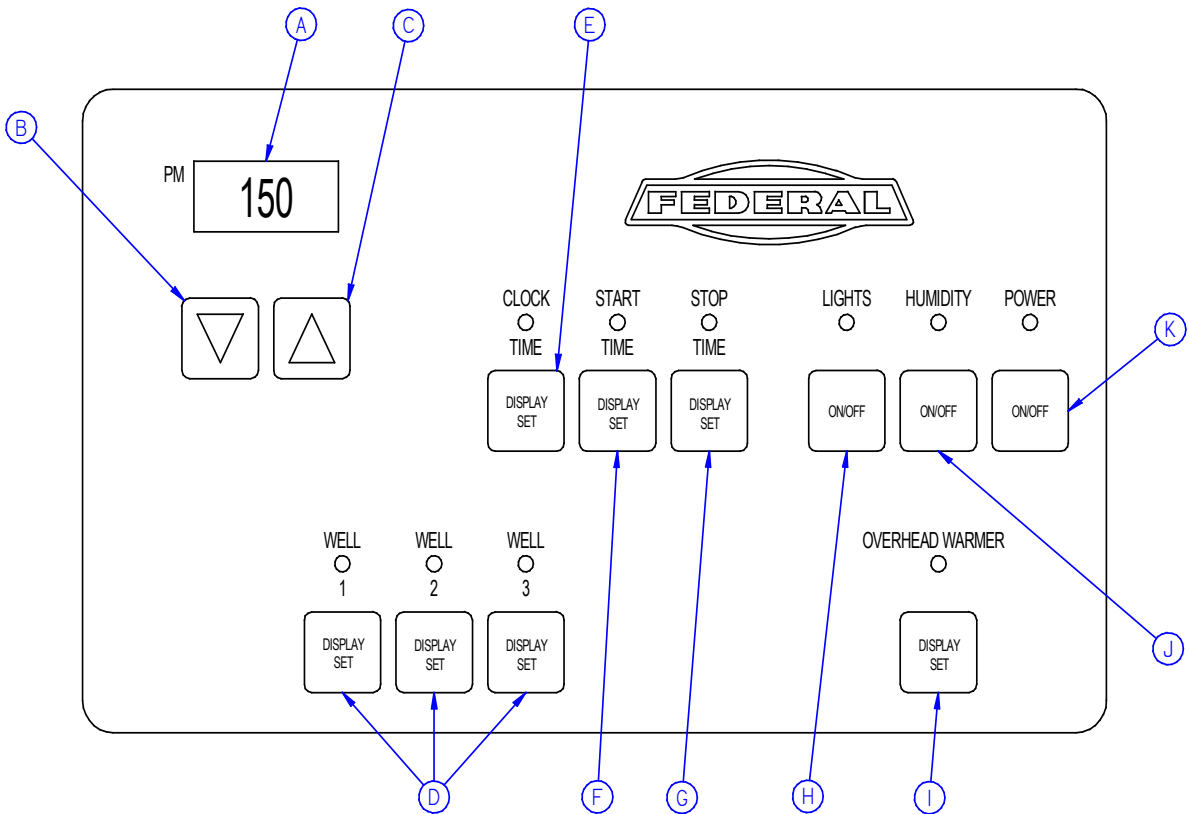

E3017

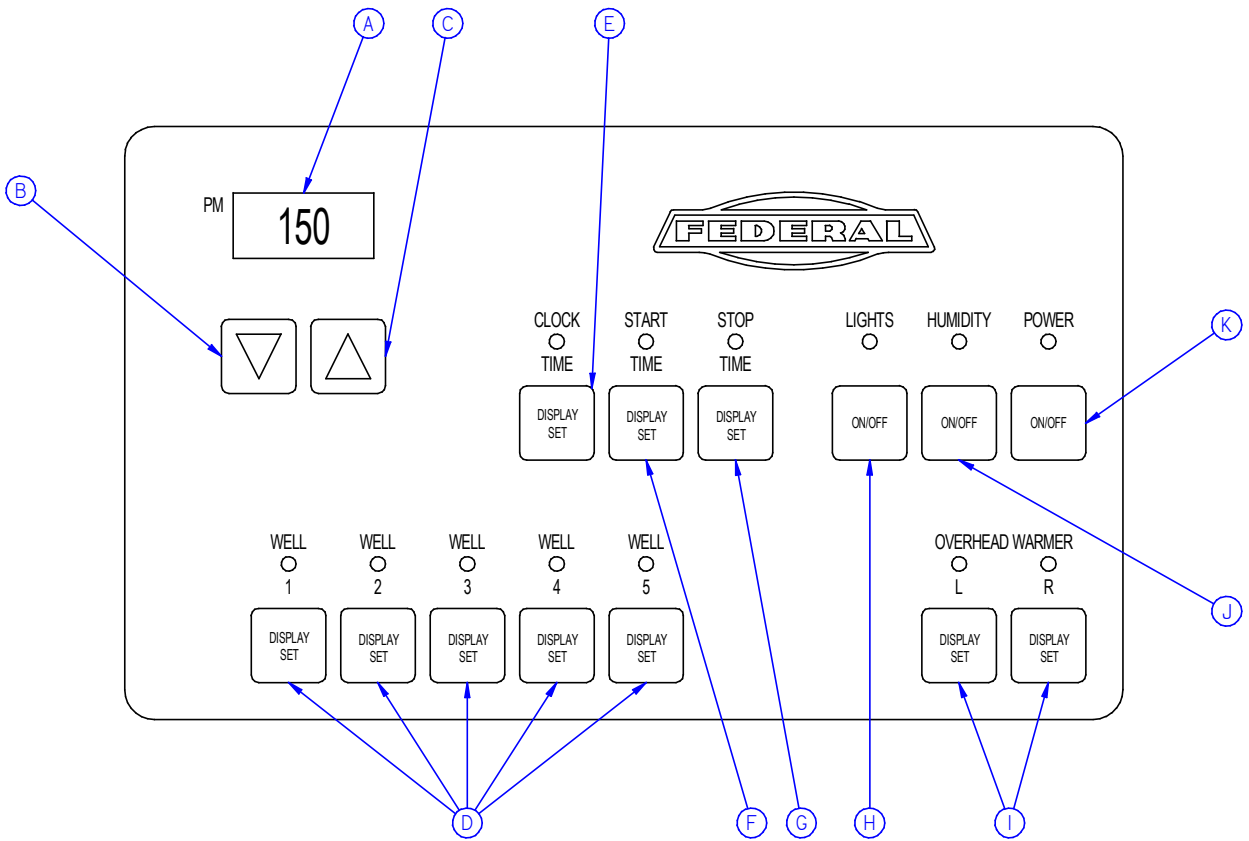

E3018

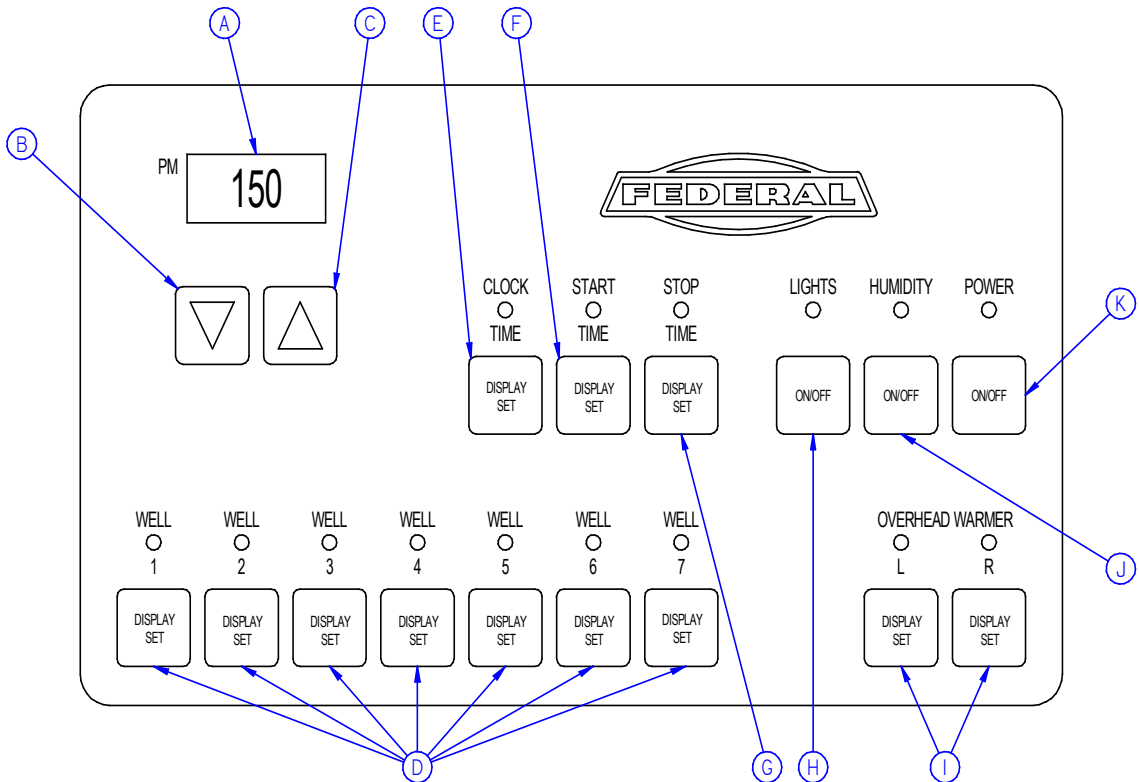

CLEANING INSTRUCTIONS

Daily Cleaning

This case should be cleaned thoroughly, as described in the weekly cleaning section, before it is used for the first time.



NOTICE: Avoid splashing or soaking any electrical components with water to prevent electrical damage to the case.



NOTICE: Shut off lights and power switches and remove all product from case. Allow sufficient time for the unit to reach room temperature before proceeding with cleaning.

NOTE: For major spills or foreign material buildup use complete weekly cleaning instructions.

1. Clean all foreign materials from the door opening.
2. Wipe complete interior of case using a damp cloth.
3. The glass can be cleaned with common window cleaners. The remaining exterior surface should be wiped down using any ammoniated cleaners or soapy warm water.

*Note: Detergents are **not** recommended.*

Weekly Cleaning

This procedure is recommended on a weekly basis. It may need to be performed more often if necessary to maintain a clean, sanitary case. The case should be cleaned to this procedure before using the first time.



NOTICE: Avoid splashing or soaking any electrical components with water to prevent electrical damage to the case.



NOTICE: Shut off lights and power switches and remove all product from case. Allow sufficient time for the unit to reach room temperature before proceeding with cleaning.

Interior Cleaning

After the unit has reached temperature – proceed as follows:

1. Remove rear doors by tilting top of frame back and lifting entire assembly out.
2. Lift up the front glass to the fully open position.
3. Lift the display pans up and take them out of the case.
4. Remove pan supports.
5. Remove thumbscrews that hold the rear vent to the back of the case.
6. Take out front glass baffle by lifting it up and out.
7. Remove front vent by lifting straight up and out.
8. Clean the entire interior of the case using warm soaping water. Wipe off all soapy water with a damp cloth and allow to dry.

Note: Depending on the amount of usage and spillage of foreign material, some fasteners may have to be removed and parts disassembled to allow proper cleaning of the unit.

9. Clean all foreign material from door tracks using warm soapy water and a brush. Apply a light film of lubricant, such as PAM, to make the doors operate smoother.
10. Clean both sides of the doors and interior of the front glass using any common window cleaner.
11. Reassemble the case in reverse order starting with Step 6.

Exterior Cleaning

1. Clean the front glass using any common window cleaner.
2. The exterior surfaces should be wiped down using any ammoniated cleansers or warm soapy water.

SERVICE INFORMATION

Before any service work is performed on the case, make sure all power is disconnected to the case.



Service problems or request for repair parts from authorized service agencies, trained service personnel, or owners should be referred to:

Warranty/Technical Service Department

Federal Industries

P.O. Box 290

Belleville, Wi 53508

Toll Free: (800) 356-4206/ WI Phone (608) 424-3331

Fax: (608) 424-3234



Pre-Service Checklist

You may avoid the cost and inconvenience of an unnecessary service call by first reviewing this checklist of frequently encountered situations that can cause unsatisfactory case performance.



CAUTION: Before servicing case, turn off power at the main breaker of fuse box.

Case Does Not Operate

- Check for disconnected power supply.
- Check for tripped breaker or blown fuse.
- Check that the power switch and well control settings are not “off”.

Lights Do Not Operate

- Check that light switch is on.
- Be sure lights are properly seated in the sockets.

Case Temperature Too Cool

- Be sure front glass is closed tightly and rear doors are in place.
- Check that all control setting on computer control are “on”.

Special Service Situations

If moisture or liquid is observed around or under a Federal Industries case, an immediate investigation should be made by qualified personnel to determine the source of the moisture or liquid. The investigation made should determine if the case is malfunctioning or if there is a simple housekeeping problem.

Moisture or liquid around or under a case is a potential slip/fall hazard for persons walking by or working in the general area of the case. Any case malfunction or housekeeping problem that creates a slip/fall hazard around or under a case should be corrected immediately.

SALE & DISPOSAL

Owner Responsibility

If you sell or give away your Federal Industries case, you must make sure that all safety labels and the Installation-Service Manual are included with it. If you need replacement labels or manuals, Federal Industries will provide them free of charge. Contact the Customer Service Department at Federal Industries at (800) 356-4206.

The Customer Service Department at Federal Industries should be contacted at the time of sale or disposal of your case so records may be kept of its new location.

ELECTRICAL DATA

ALL MODELS ARE 120/208-240 VOLT, 1 PHASE, 60 HERZE

	SQ3HCD	SQ4HD	SQ6HD	SQ8HD
	AMPS	AMPS	AMPS	AMPS
Well Heaters	5.5	8.3	13.9	19.4
Overhead Warmer	2.5	3.5	5.0	7.1
Fan	0.3 ea.(1)	0.3 ea.(1)	0.3 ea.(2)	0.3 ea.(2)
Lights	1.0	1.5	2.5	3.5
Humidity System	1.7	1.7	1.7	1.7

Refer to the rating plate data attached to the rear of the case for Maximum Fuse Size and Minimum Circuit Ampacity.

Each model is equipped with a general-purpose receptacle, which requires a separate electrical circuit of 120V, 15 Amps. This receptacle must be wired in accordance with the National Electrical Code.

REPLACEMENT PARTS

MODELS: **SQ3HD, SQ4HD, SQ6HD & SQ8HD**

Part Description

Part Number

Electrical Components

Fan Motor	41-13776	41-13776	41-13776	41-13776
Light Bulb	42-11248	42-11248	42-11248	42-11248
Lamp Holder	42-13649	42-13649	42-13649	42-13649
Ribbon Cable (8 Pin)	41-13767	41-13767	41-13767	41-13767
Ribbon Cable (12 Pin)	41-13766	41-13766	41-13766	41-13766
Temperature Probe	41-13755	41-13755	41-13755	41-13755
Logic Board	41-13744	41-13744	41-13744	41-13744
Relay Board	41-13747	41-13747	41-13749	41-13749
Well Heater	40-13074	40-13074	40-13074	40-13074
Overhead Heater	40-13277	40-13278	40-13277	40-13278

Humidity System

Solenoid Valve	41-30106	41-30106	41-30106	41-30106
Humidity Pan	SA-2316	SA-2316	SA-2316	SA-2316
Float	72-13758	72-13758	72-13758	72-13758
Heater	40-13276	40-13276	40-13276	40-13276
Water Needle Valve	82-15030	82-15030	82-15030	82-15030

REPLACEMENT PARTS

MODELS: SQ3HD, SQ4HD, SQ6HD & SQ8HD

Part Description	Part Number			
<u>Misc. Components</u>	<u>SQ3HD</u>	<u>SQ4HD</u>	<u>SQ6HD</u>	<u>SQ8HD</u>
Rear Door Glass	15-14148	15-14149	15-14150	15-14151
Front Curved Glass	50-13028	50-13029	50-12830	50-13831
Side Glass	51-13124	51-13124	51-13124	51-13124
Glass Baffle	51-13161	51-13162	51-13764	51-13765
Gas Cylinder	81-13660	81-13661	81-13661	81-13661
Decal – Elect Hazard	91-10743	91-10743	91-10743	91-10743
Federal Logo Sticker	91-72523	91-72523	91-72523	91-72523
Mirrored Side Glass(Left)	55-13249	55-13249	55-13249	55-13249
Mirrored Side Glass (Right)	55-13248	55-13248	55-13248	55-13248
Fan Guard	64-13831	64-13831	64-13831	64-13831
Fan Blade	72-13777	72-13777	72-13777	72-13777
Decal – Caution Hot	91-10207	91-10207	91-10207	91-10207
Decal – Unit Must Be Grounded	91-10875	91-10875	91-10875	91-10875
Decal – Lamp Replacement	91-13762	91-13762	91-13762	91-13762

**WIRING DIAGRAM - SQ3HD, SQ4HD,
SQ6HD & SQ8HD**

WIRING DIAGRAM - RECEPTACLE

California Residents Only.

 **WARNING**

This product can expose you to chemicals including chromium which is known to the State of California to cause cancer and birth defects or other reproductive harm. For more information go to

www.P65Warnings.ca.gov