



The Signature of Quality®

FEDERAL INDUSTRIES

A Standex Company

215 Federal Avenue
Belleville, Wisconsin 53508-9201

Phone: 800-356-4206

Fax: 608-424-3234

Email: Geninfo@Federalind.com

Website: Federalind.com

Project Name: _____

Item #: _____

Model #: _____ Qty: _____

Approval: _____

AIA #

SIS #

VISION SERIES - Square Ends Self-Serve Heated Slide-In Display Case - 60"

Designed with impulse sales in mind. Get maximum return from an attention-grabbing case and increase profits.



Square model shown

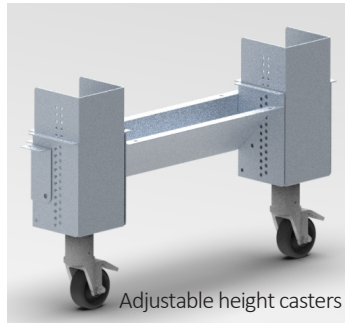

Adjustable height casters

MODEL	DIMENSIONS (Includes End Panels)
<input type="checkbox"/> VHSS2460S-SLD	24 x 33 x 60 (in) 610 x 838 x 1524 (mm)
<input type="checkbox"/> VHSS3660S-SLD	36 x 33 x 60 (in) 914 x 838 x 1524 (mm)
<input type="checkbox"/> VHSS4860S-SLD	47.25 x 33 x 60 (in) 1200 x 838 x 1524 (mm)

STANDARD FEATURES

Model Features

- Stainless steel interior including shelves
- Stainless steel heated display deck
- Removable heated deck
- Black powder coated base frame
- Tempered glass ends
- Black trim
- Adjustable height casters (32" to 38" counter height) with locks
- Cord & plug

Heating System

- Independently controlled heated shelves and deck, that are easily adjusted or replaced.
- Holds product up to an average temperature of 160°F (71°C)
- Easy rear access microprocessor digital temperature controls

Shelving

- 3 heated tiers of adjustable stainless-steel shelves with price tag molding on 1 1/8" centers
- Shelves can be flat or slanted down at 10°

Lighting

- 3500K LED top light

Agency Approvals

- UL, C-UL, and NSF4

OPTIONAL ACCESSORIES

- 3500K LED lights below shelves
- Stainless steel exterior finish
- Premium exterior laminate
- Graphics package
- Solid end panels (mirrored interior)
- Reflective end glass
- Clear or reflective sliding rear doors (solid hinged on 24" cases)

*Additional options available on the website and price list



WARRANTY*
One year Parts and Labor
2nd thru 5th year part only
service compressor
(U.S.A. and Canada)

Note: Information is subject to change at any time. Visit www.federalind.com for the most current specs.

AIA #	VISION SERIES - Square Ends Self-Serve Heated Slide-In Display Case - 60"
SIS #	Product Specifications

Zone	Intended Product to be Displayed	Warmest Ave. Prod. Temp. °F/°C
All	Packaged Heated Merchandise	160°F/[71.1°C]

DIMENSION: xx"/(mm)
 DIMENSION TOLERANCE +/- 0.25 (6.4)

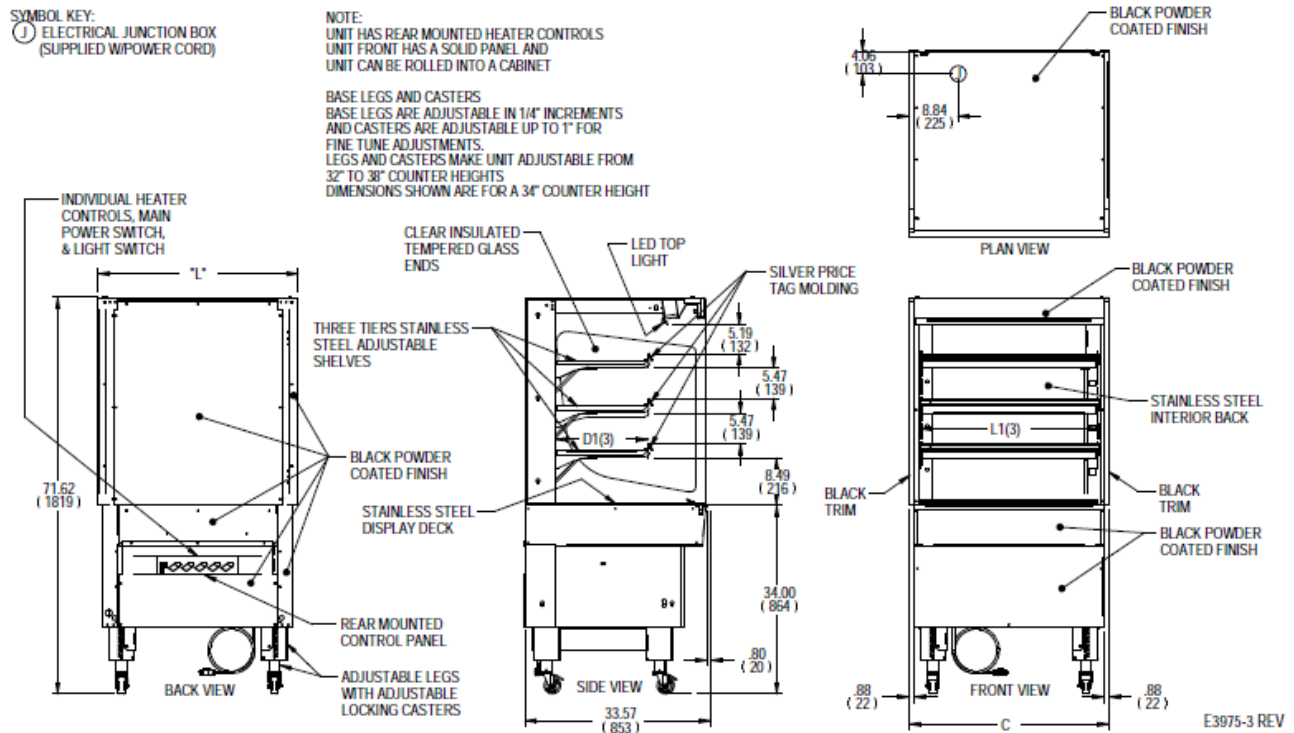

MODEL	DIMENSIONS				COUNTER CUTOUT	SHELVING			INTERIOR VOLUME CU FT	STANDARD CONNECTION CORD & PLUG			SHIP WEIGHT
	L	D	H	C		# OF TIERS	L1	D1		2 WIRE + GROUND		NEMA CORD & PLUG	
	in	in	in	in			in	in		208-240/60/1	MAX FUSE SIZE		
	mm	mm	mm	mm			mm	mm		AMPS			
VHSS2460S-SLD	24	33	60	22.5	23.25	3	32.25	16.61	6.0 @ 208	15	NEMA 6-15P	310	
	610	838	1524	572	591		819	422					6.9 @ 240
VHSS3660S-SLD	36	33	60	34.5	35.25	3	43.25	16.61	9.7 @ 208	15	NEMA 6-15P	355	
	914	838	1524	876	895		1099	422					11.1 @ 240
VHSS4860S-SLD	47.25	33	60	45.5	46.25	3	55.25	16.61	13.4 @ 208	20	NEMA 6-20P	490	
	1200	838	1524	1156	1175		1403	422					15.4 @ 240

- Packaged food products placed in case must be pre-heated before placing in case
- Due to continuing engineering improvements, specifications are subject to change without notice



FEDERAL INDUSTRIES
 A Standex Company
 215 Federal Avenue Belleville, Wisconsin 53508-9201

Phone: 800-356-4206
Fax: 608-424-3234
Email: Geninfo@Federalind.com
Website: Federalind.com