



The Signature of Quality

FEDERAL INDUSTRIES

A Standex Company

215 Federal Avenue
Belleville, Wisconsin 53508-9201

Phone: 800-356-4206

Fax: 608-424-3234

Email: Geninfo@Federalind.com

Website: Federalind.com

Project Name: _____

Item #: _____

Model #: _____ Qty: _____

Approval: _____

AIA #

SIS #

Refrigerated Self-Serve Slim-Line High Profile Specialty Merchandiser – 78”H X 24” W

Designed with impulse sales in mind. Get maximum return from an attention-grabbing merchandiser and increase profits.



Model RSSL478SC Shown

MODEL	DIMENSIONS <small>(Includes End Panels)</small>
<input type="checkbox"/> RSSL378SC	36 x 24 x 78 (in) 914 x 607 x 1981 (mm)
<input type="checkbox"/> RSSL478SC	47.25 x 24 x 78 (in) 1200 x 607 x 1981 (mm)
<input type="checkbox"/> RSSL578SC	59.25 x 24 x 78 (in) 1505 x 607 x 1981 (mm)
<input type="checkbox"/> RSSL678SC	71.25 x 24 x 78 (in) 1810 x 607 x 1981 (mm)

STANDARD FEATURES

Model Features

- Welded powder coated steel base fabrication
- Choice of standard laminates on exterior
- Black metal front grill and galvanized steel back
- Silver trim
- Stainless steel display deck, glass and black interior ends, black interior back panel
- Moisture resistant end panel construction with field replaceable tempered thermo-pane glass
- Front air intake and discharge
- Energy saving night curtain
- Cord and plug, self-contained only
- Adjustable leg levelers

Refrigeration

- Electronic temperature control with on demand defrost
- PTC Condensate heater provided for a totally self-contained system (3.3°-4.4°C)
Note: Case temperature will vary if the air curtain is disrupted.
- Insulated with high-density urethane foam
- Thermometer
- Refrigeration controls maintain 38°-40°F
- R449a refrigerant (R448a/R449a in Remote Applications)

Shelving

- Four tiers of adjustable black metal shelves with price tag molding. Shelves can be flat or slanted downwards at 10°

Lighting

- 3500K LED top light
- DLC certified, IP 65 rated

Agency Approvals

- UL, C-UL and UL Sanitation listed to NSF-7, Type I conditions
- DOE 2017 compliant

OPTIONAL ACCESSORIES

- Special exterior laminate finish
- Stainless steel exterior finish
- Black or white trim
- White interior (including shelving)
- Stainless steel interior (including shelving)
- Additional Lighted (LED) shelf
- Reflective end glass
- Deli meat pegs
- Security night cover - removable
- LED lights below shelves
- 2 1/2" (63.5 mm) casters (self-contained models only)
- Legs 6" (152mm)
- Skirt with casters or legs
- Condensate pump
- Condensate evaporator assembly (Field install) (Separate 120V, 20A circuit required) (Remote only)
- Remote refrigeration with condensate pump (EEV included)

*Additional options available on the website and price list.



WARRANTY*
One year Parts and Labor
2nd thru 5th year part only
service compressor
(U.S.A. and Canada)

Note: Information is subject to change at any time. Visit www.federalind.com for the most current specs.

AIA #	Refrigerated Self-Serve Slim-Line High Profile Specialty Merchandiser – 78”H X 24” W
SIS #	Product Specifications

Intended Environment: Type I (Self Contained) - Designed to operate in maximum ambient conditions of 75°F (24°C) and 55% relative humidity. Type II (Remote) - Designed to operate in maximum ambient conditions of 80°F (24°C) and 55% relative humidity		
Zone	Intended Product To Be Displayed	Avg prod temp °F / °C
All	Packaged Refrigerated Products	38°F / (3.3°C)

DIMENSION: xx"/(mm)
DIMENSION TOLERANCE: +/- 0.25 (6.4)

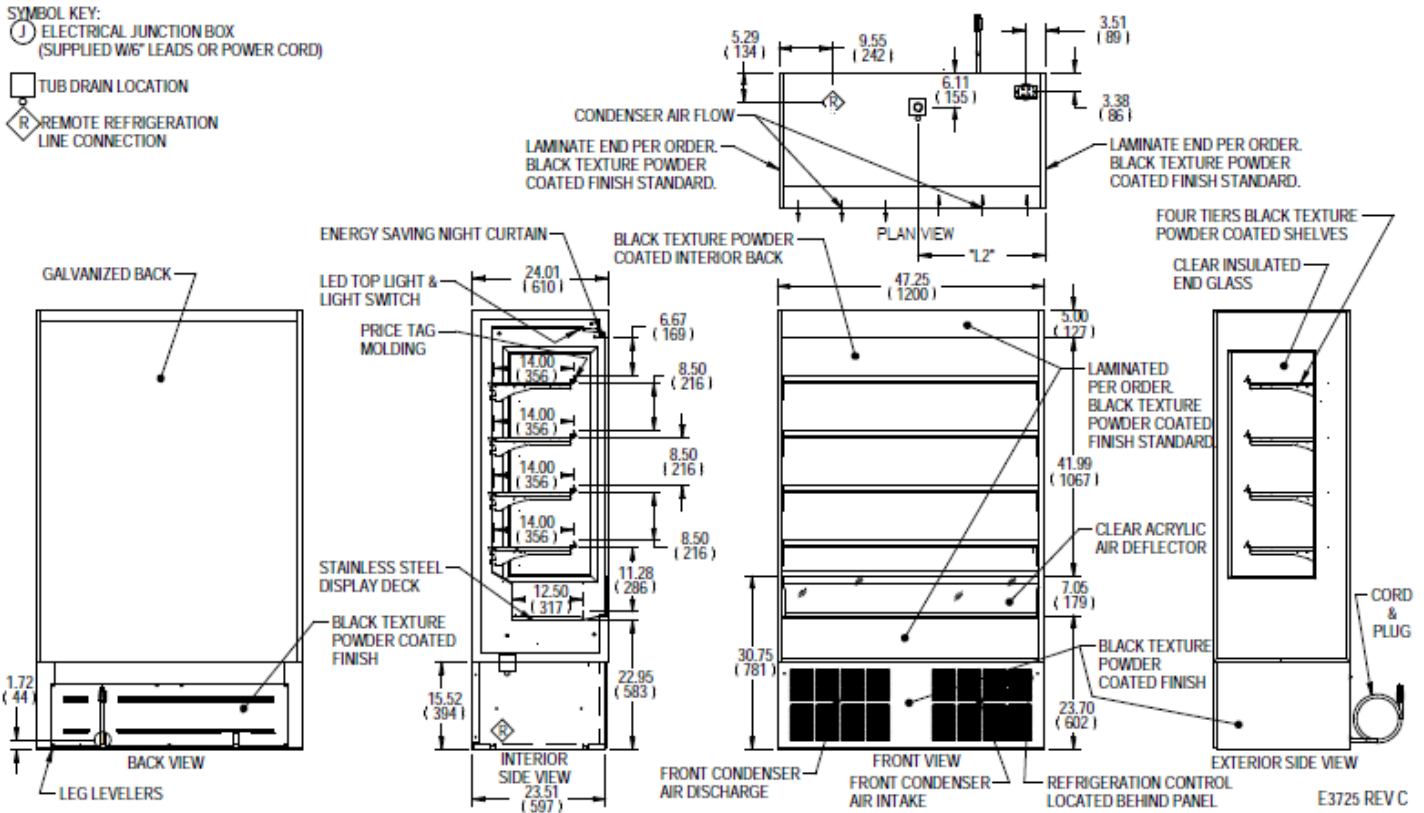
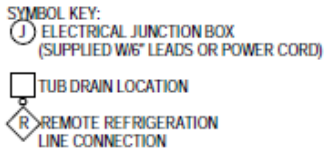

MODEL	DIMENSION			TUB DRAIN L2	SHELVING			INTERIOR VOLUME CU FT	SELF CONTAINED				REMOTE								
	L	D	H		# OF TIERS	D	L		STANDARD NEMA CORD & PLUG				REFRIGERANT	C.U. HP	SHIP WEIGHT LBS	PERMANENT CONNECT			BTU'S @+20°	SHIP WEIGHT KILLO	
	2-WIRE + GROUND								ELECTRICAL	AMPS	MAX FUSE SIZE	NEMA CORD & PLUG				2-WIRE + GROUND					
	in	in	in		in	in	in									in	in	in			in
RSSL378	36.00	24.00	78.00	11.63	4	14.00	34.00	16.09	120/60/1	16.0	20	NEMA 5-20P	R449a	3/4	795 LBS	6.4	120/60/1	15	R449a	5400	740 LBS
	914	610	1981	295	356	864	361 KILO														
RSSL478	47.25	24.00	78.00	22.63	4	14.00	45.00	21.23	120/60/1	16.0	20	NEMA 5-20P	R449a	3/4	885 LBS	7.6	120/60/1	15	R449a	7500	800 LBS
	1200	610	1981	575	356	1143	401 KILO														
RSSL578	59.25	24.00	78.00	29.13	4	14.00	57.00	26.82	208-240/60/1	15.0	20	NEMA 6-20P	R449a	1	1120 LBS	7.3	208-240/60/1	15	R449a	9000	1015 LBS
	1505	24	1981	740	356	1448	508 KILO														
RSSL678	71.25	24.00	78.00	35.13	4	14.00	69.00	32.42	208-240/60/1	15.0	20	NEMA 6-20P	R449a	1	1180 LBS	7.3	208-240/60/1	15	R449a	10500	1075 LBS
	1810	610	1981	892	356	1753	535 KILO														

- Due to continuing engineering improvements, specifications are subject to change without notice.
- Case temperature will vary if the air curtain is disrupted.



FEDERAL INDUSTRIES
 A Standex Company
 215 Federal Avenue Belleville, Wisconsin 53508-9201

Phone: 800-356-4206
Fax: 608-424-3234
Email: Geninfo@Federalind.com
Website: Federalind.com