



*The Signature of Quality*

### FEDERAL INDUSTRIES

A Standex Company  
215 Federal Avenue  
Belleville, WI 53508-9201

Phone: 800-356-4206  
Fax: 608-424-3234  
Email: geninfo@federalind.com  
Website: www.federalind.com

Project Name: \_\_\_\_\_

Item #: \_\_\_\_\_

Model #: \_\_\_\_\_ Qty: \_\_\_\_\_

Approval: \_\_\_\_\_

AIA#

SIS#

## HYBRID MERCHANDISER

### SERVICE REFRIGERATED OVER SELF-SERVE REFRIGERATED

Display more product and serve more customers with presentation and value in mind.



MODEL	DIMENSIONS ( Includes End Panels )
<input type="checkbox"/> CRR3628/RSS3SC	36.25 x 43.25 x 72.50 (in) 921 x 1099 x 1842 (mm)
<input type="checkbox"/> CRR4828/RSS4SC	48 x 43.25 x 72.50(in) 1219 x 1099 x 1842 (mm)

### STANDARD FEATURES

#### Refrigerated Self-Serve Bottom Display

- Black laminated exterior. Other finishes available.
- Black trim. Silver optional.
- Black interior, glass ends.
- Horizontal LED top and front light.
- Two tiers black metal shelves.
- Cord and plug.
- Thermometer
- R513a Refrigerant

#### Service Refrigerated Top Display

- Service Refrigerated Top Display
- Two tiers black wire shelves.
- Sliding rear doors.
- Black trim.
- Thermometer
- R513a Refrigerant

#### Lighting

- LED top light and shelf lights.

#### Agency Approvals

- UL Safety and UL Sanitation Listed to NSF Type II conditions.
- DOE 2017 Compliant

### OPTIONAL ACCESSORIES

#### For Top Display

- Glass Shelves
- Reflective Ends
- Reflective Rear Doors

#### For Self-Serve Refrigerated Base

- Energy Saving Night Curtain
- Silver Trim
- Special Base Finish
- Mirrored Interior Ends
- Security Night Cover
- Stainless Steel Steps in Lieu of Metal Shelves
- Reflective End Glass



**WARRANTY\***  
One year Parts and Labor  
2nd thru 5th year part  
only service compressor  
(U.S.A and Canada)

Note: Information is subject to change at any time.  
Visit [www.federalind.com](http://www.federalind.com) for the most current specs.

Revised 04/07/2021

AIA#	<b>HYBRID MERCHANDISER</b>
SIS#	<b>Product Specifications</b>

Intended Environment: Type I - Designed to operate in maximum ambient conditions of 75°F (24°C) and 55% relative humidity unless noted otherwise in system information below.

Zone	Intended Product To Be Displayed	Avg Prod Temp °F/°C
All	Packaged Refrigerated Products	38°F / (3.3°C)

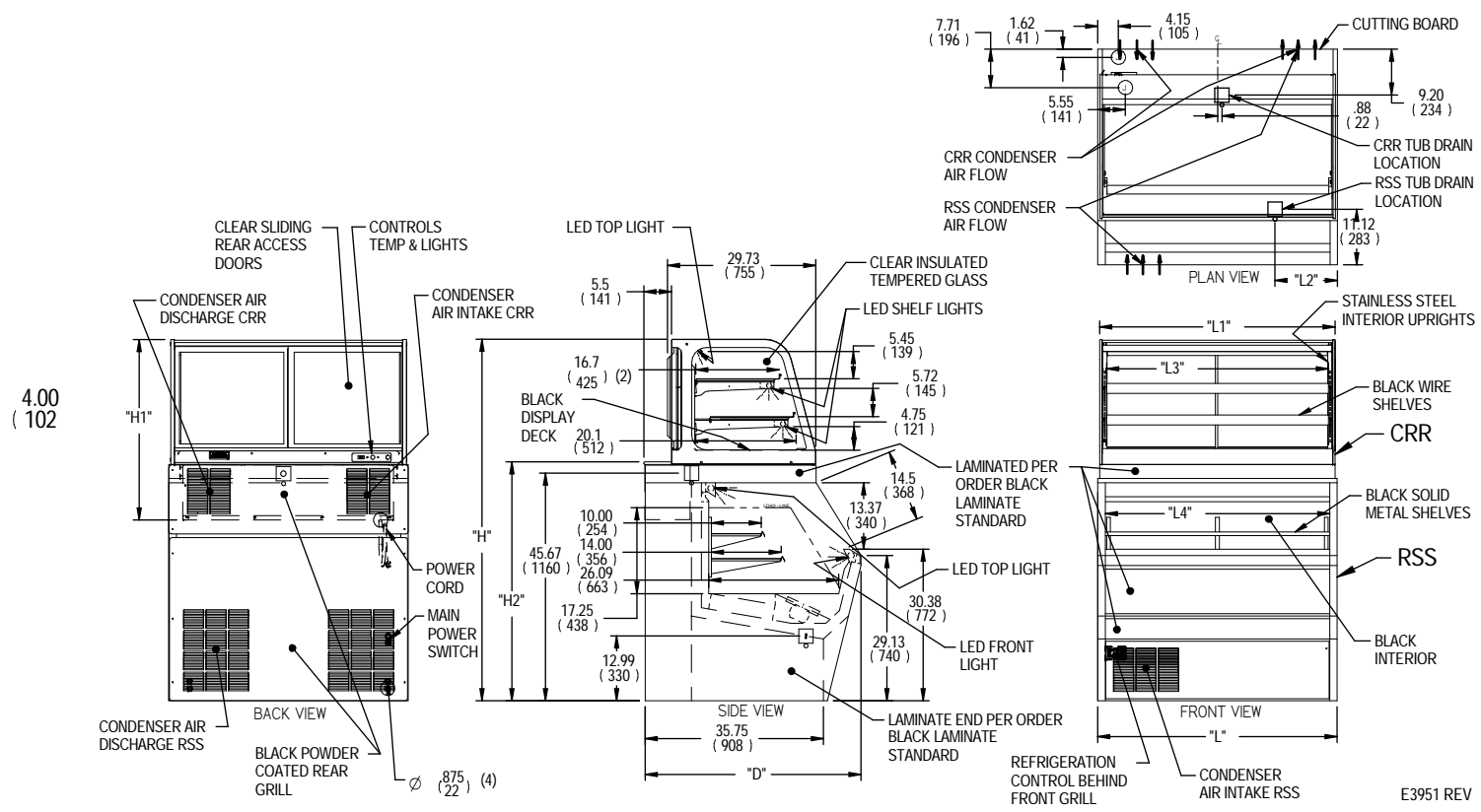

E3951 REV

MODEL	HYBRID INFO			SELF CONTAINED														
	DIMENSION			INDIVIDUAL CASE	DIMENSION			TUB DRAIN	SHELVING			INTERIOR VOLUME CU FT	ELECTRICAL			REFRIGERANT	C.U. HP	SHIP WEIGHT
	L	D	H		L1	H1	H2	L2	# OF TIERS	L3	L4		2-WIRE + GROUND 120/60/1					
	in	in	in	QTY	in	in	in	in	in	in	AMPS	MAX FUSE SIZE	CONNECTION TYPE	LBS	KILO			
mm	mm	mm		mm	mm	mm	mm		mm	mm								
CRR3628/RSS3SC	36.25	43.25	72.50	CRR3628	36.0	36.2			2	32.2		9.25	8.1	15	NEMA 5-15P CORD & PLUG	R513a	1/3	847 LBS
				1	914	919				818								
	921	1099	1842	RSS3SC			47.91	12.5	2	33.3		7.18	16	20	NEMA 5-20P CORD & PLUG	R513a	1/2	384 KILO
			1			1217	318		845									
CRR4828/RSS4SC	48.00	43.25	72.50	CRR4828	48.0	36.2			2	44.2		12.50	8.3	15	NEMA 5-15P CORD & PLUG	R513a	1/3	1010 LBS
				1	1219	919				1123								
	1219	1099	1842	RSS4SC			47.91	12.5	2	45.0		9.72	16	20	NEMA 5-20P CORD & PLUG	R513a	1/2	458 KILO
			1			1217	318		1143									

- On the six foot display a separate 120/60/1 15 AMP circuit is required for the condensate evaporator.
- Refrigerated cases are designed to operate in a maximum of 75°F (24°C) ambient and 55% relative humidity.
- Due to continuing engineering improvements, specifications are subject to change without notice.
- If a GFCI circuit is required, a GFCI Breaker Must be used instead of GFCI receptacle.



**FEDERAL INDUSTRIES**  
 A Standex Company  
 215 Federal Avenue Belleville, Wisconsin 53508-9201

**Phone:** 800-356-4206  
**Fax:** 608-424-3234  
**Email:** Geninfo@Federalind.com  
**Website:** Federalind.com